





DETALII TEHNICE

Profile Zincate



I.	Prezentare generală	2
II.	Caracteristici tehnice profile zincate TeraSteel	
	 II.1 Profil Z	
	1.1. Caracteristici generale	4
	1.2. Dimensiuni secționale și geometrice	4
	1.3. Metoda de montaj	9
	1.4. Încărcări statice	10
	 II.2 Profil C	
	2.1. Caracteristici generale	31
	2.2. Dimensiuni secționale și geometrice	31
	2.3. Metoda de montaj	36
	2.4. Încărcări statice	37
	 II.3 Profil Σ	
	3.1. Caracteristici generale	44
	3.2. Dimensiuni secționale și geometrice	44
	3.3. Metoda de montaj	49
	 II.4 Profil U	
	4.1. Caracteristici generale	50
	4.2. Dimensiuni secționale și geometrice	50
	4.3. Metoda de montaj	53
III.	Profile ghidaj și aliniere L, Ω ,U 	56
IV.	Hale la cheie	58
V.	Fâșii zincate	61

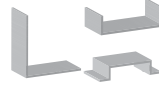

I. PREZENTARE GENERALĂ

Informații generale

TeraSteel este producătorul numărul 1 de panouri termoizolante și de profile zincate din România și Serbia.

Avem peste 25 de ani de experiență pe piața materialelor de construcții și mai bine de 15 ani în producția de panouri termoizolante și profile zincate. Compania noastră activează în trei unități de producție situate în România și Serbia. În prezent, putem oferi soluții complete pentru construcții industriale, la cele mai înalte standarde.

- panouri termoizolante de perete și acoperiș cu spumă poliuretanică PUR, ignifugată PIR (RF, XV), LEAD și cu vată minerală MW;
- profile zincate de tip C, Z, U și Σ ;
- tablă cutată autoportantă TRS 153-840 și 85-1120;
- hale la cheie.

În conformitate cu standardele europene, activitatea firmei se desfășoară în Sistem de Management Integrat Calitate-Mediu-Sănătate și Securitate ocupațională - organism certicator SGS Romania.



Profilele ușoare din oțel zincat formate la rece sunt o categorie de produse pentru construcții care se dezvoltă foarte rapid datorită avantajelor pe care le prezintă.

TeraSteel oferă sisteme din profilele de tip Z, C, U și Σ cu înălțimea secțiunilor de la 100 mm până la 400 mm, cu grosimi de la 1 la 4 mm, și lungimi de la 2 m la 13,5 m (sau chiar și lungimi agabaritice).

Profilele formate la rece pot fi folosite atât ca:

- a) elemente structurale din oțel pentru lucrări de construcții civile, industriale, agricole;
- b) elemente secundare ale structurilor de rezistență ale clădirilor ca pane pentru acoperiș sau rigle pentru pereți;

Materialul de bază este tabla din oțel zincat, conforma cu standardele SR EN 10143 și SR EN 10346:2015.

Toleranțele la formă și dimensiuni respectă cerințele standardelor SR EN 10162 și SR EN 1090-2.

Caracteristicile de performanță ale produselor sunt în conformitate cu standardele SR EN 1090-1+A1:2012; SR EN 1090-2+A1:2012 și proiectele de execuție.

Profilele pot fi realizate cu pregătire automată, conform cerințelor din proiect. Profilele ușoare din oțel zincat se obțin prin formarea progresivă la rece a fâșiilor de tablă zincată la cald, care trec prin mai multe seturi de role.

Particularitățile sistemului din profile zincate

Utilizarea unor profile formate din tablă subțire înseamnă practic oțel mai puțin iar varietatea mare de dimensiuni care se pot obține (se pot forma profile personalizate chiar în serii mici, fără creșteri substanțiale de cost) permite proiectanților să ajungă la configurații structurale bine optimizate și implicit mai ieftine.

Domenii de utilizare

Clădiri care se pretează foarte bine pentru acest sistem constructiv:

- hale de depozitare;
- hale în care se desfășoară procese de producție;
- hale în care se desfășoară diverse servicii (service auto, spălătorii auto, ateliere mici, ferme cu aplicații în agricultură);

Se utilizează în domeniul construcțiilor, ca și componente la alcătuirea:

- structuri principale (cadre cu stâlpi și grinzi);
- structuri secundare (pentru susținerea invelitorilor și închiderilor);
- grinzilor pentru planșee intermediare;
- fermelor zăbrelete (secțiuni compuse C și/sau Σ);
- supraetajărilor, mansardărilor.

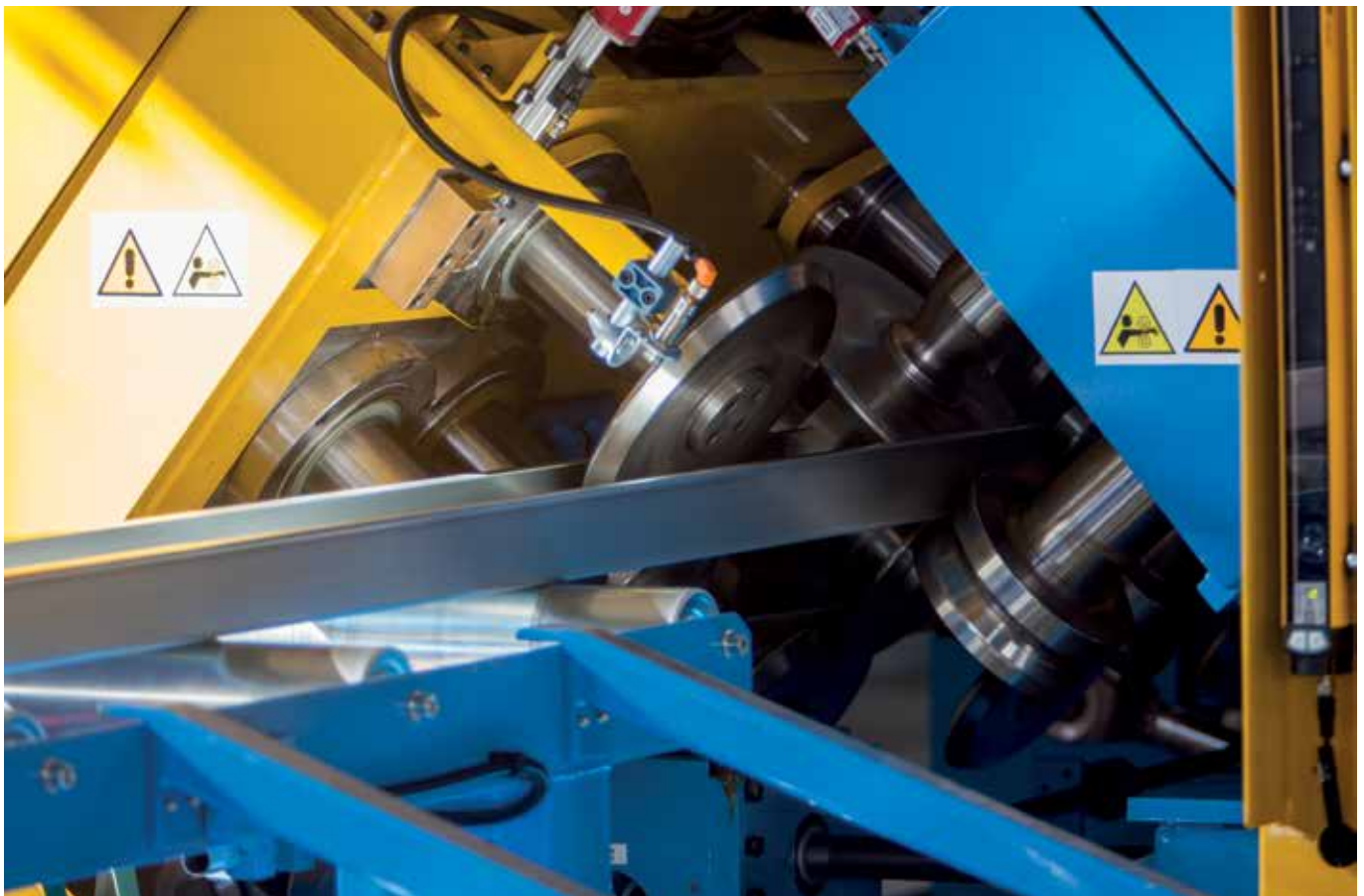
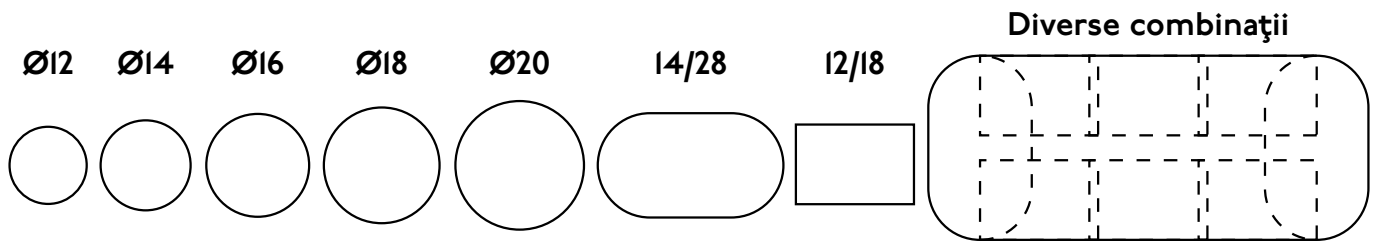



II.1 PROFIL Z

1.1 Caracteristici generale

Se utilizează în special ca pane de acoperiș

Caracteristici tehnice

- înălțimea secțiunilor: 100-400 mm;
- $b_1, b_2 = 38\div 100\text{mm}$; $c_1, c_2 = 13\div 30\text{mm}$; $(c_1/b_1) \text{ max}=0.4$; $(c_2/b_2) \text{ max}=0.4$; $(b_1, b_2/ h) \text{ max}=0.5$; $r=4 \text{ mm}$;
- unghiurile de îndoire $=90^\circ$;
- grosimi: de la 1- la 4 mm;
- lungimi de tăiere standard: 2000- 13500 mm; pentru alte lungimi vă rugăm contactați departamentul tehnic TeraSteel.
- profilele pot fi realizate cu pregătire automată;
- profilele pot fi realizate cu laturi egale sau inegale;
- calitate material: S350GD+Z275.

1.2 Dimensiuni secționale și caracteristici geometrice

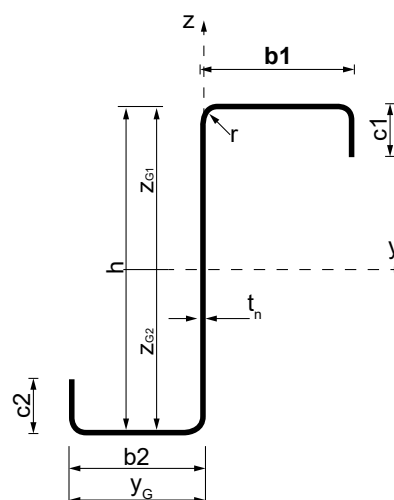

	TIP	Dimensiuni secționale							
		h (mm)	b ₁ (mm)	b ₂ (mm)	c (mm)	t _n (mm)	t (mm)	r _i (mm)	G (kg/m)
Z100	Z100-1.5	100	47	40	17.1	1.5	1.42	4.0	2.44
	Z100-2	100	47	40	18.3	2	1.91	4.0	3.25
Z120	Z120-1.5	120	47	40	17.1	1.5	1.42	4.0	2.67
	Z120-2	120	47	40	18.3	2.0	1.91	4.0	3.56
	Z120-2.5	120	47	40	19.5	2.5	2.40	4.0	4.45
Z150	Z150-1.5	150	47	40	17.1	1.5	1.42	4.0	3.03
	Z150-2	150	47	40	18.3	2.0	1.91	4.0	4.04
	Z150-2.5	150	47	40	19.5	2.5	2.40	4.0	5.04
Z180	Z180-1.5	180	60	53	20.6	1.5	1.42	4.0	3.77
	Z180-2	180	60	53	21.8	2.0	1.91	4.0	5.02
	Z180-2.5	180	60	53	23.0	2.5	2.40	4.0	6.28
Z200	Z200-1.5	200	72	65	23.6	1.5	1.42	4.0	4.36
	Z200-2	200	72	65	24.8	2.0	1.91	4.0	5.81
	Z200-2.5	200	72	65	26.0	2.5	2.40	4.0	7.26
Z250	Z250-1.5	250	72	65	23.6	1.5	1.42	4.0	4.95
	Z250-2	250	72	65	24.8	2.0	1.91	4.0	6.59
	Z250-2.5	250	72	65	26.0	2.5	2.40	4.0	8.24
	Z250-3	250	72	65	27.2	3.0	2.90	4.0	9.89
Z300	Z300-2	300	88	81	23.8	2.0	1.91	4.0	7.85
	Z300-2.5	300	88	81	25.0	2.5	2.40	4.0	9.81
	Z300-3	300	88	81	26.2	3.0	2.90	4.0	11.77
Z350	Z350-2	350	100	93	24.8	2.0	1.91	4.0	9.04
	Z350-2.5	350	100	93	26.0	2.5	2.40	4.0	11.30
	Z350-3	350	100	93	27.2	3.0	2.90	4.0	13.56
	Z350-3.5	350	100	93	28.5	3.5	3.40	4.0	15.83
	Z350-4	350	100	93	29.7	4.0	3.90	4.0	18.09
Z400	Z400-2	400	100	93	24.8	2.0	1.91	4.0	9.83
	Z400-2.5	400	100	93	26.0	2.5	2.40	4.0	12.28
	Z400-3	400	100	93	27.2	3.0	2.90	4.0	14.74
	Z400-3.5	400	100	93	28.5	3.5	3.40	4.0	17.20
	Z400-4	400	100	93	29.7	4.0	3.90	4.0	19.66

	TIP	Caracteristici geometrice ale secțiunii brute										
		A(mm ²)	Y _G (mm)	Z _{G1} (mm)	Z _{G2} (mm)	I _y (mm ⁴)	W _{y1} (mm ³)	W _{y2} (mm ³)	I _z (mm ⁴)	I _t (mm ⁴)	i _y (mm)	i _z (mm)
Z100	Z100-1.5	293.5	40.5	47.6	51.0	450,736.61	9,465.16	8,845.01	142,195.27	197.26	39.2	22.0
	Z100-2	394.7	40.0	47.4	50.7	596,284.67	12,584.16	11,759.59	191,248.57	479.99	38.9	22.0
Z120	Z120-1.5	321.9	40.3	57.5	61.1	693,190.96	12,064.08	11,341.31	142,289.29	216.35	46.4	21.0
	Z120-2	432.9	39.8	57.2	60.9	920,079.50	16,079.26	15,115.85	191,376.63	526.44	46.1	21.0
	Z120-2.5	543.9	39.4	57.0	60.6	1,140,352.68	20,011.84	18,812.70	240,257.24	1,044.35	45.8	21.0
Z150	Z150-1.5	364.5	40.1	72.3	76.3	1,179,328.70	16,319.72	15,453.23	142,402.84	244.98	56.9	19.8
	Z150-2	490.2	39.6	72.0	76.1	1,570,469.44	21,804.34	20,646.56	191,531.30	596.12	56.6	19.8
	Z150-2.5	615.9	39.2	71.8	75.8	1,953,056.27	27,206.24	25,761.52	240,454.04	1,182.59	56.3	19.8
Z180	Z180-1.5	466.5	53.2	87.4	91.2	2,276,862.08	26,054.80	24,967.63	330,980.18	313.55	69.9	26.6
	Z180-2	628.3	52.7	87.2	90.9	3,045,336.97	34,943.55	33,487.39	446,355.91	764.05	69.6	26.7
	Z180-2.5	790.6	52.2	86.9	90.7	3,804,381.69	43,772.33	41,950.65	562,012.31	1,517.88	69.4	26.7
Z200	Z200-1.5	537.5	65.2	97.5	101.1	3,307,434.72	33,938.48	32,706.02	579,901.94	361.27	78.4	32.8
	Z200-2	723.8	64.8	97.2	100.9	4,425,864.66	45,526.34	43,874.95	782,100.45	880.18	78.2	32.9
	Z200-2.5	910.6	64.3	97.0	100.6	5,531,902.47	57,043.38	54,976.59	984,982.16	1,748.28	77.9	32.9
Z250	Z250-1.5	608.5	65.0	122.3	126.3	5,588,723.17	45,711.90	44,242.47	580,075.55	408.99	95.8	30.9
	Z250-2	819.3	64.6	122.0	126.1	7,490,569.07	61,387.66	59,416.31	782,335.88	996.31	95.6	30.9
	Z250-2.5	1030.6	64.1	121.8	125.8	9,377,819.49	77,005.08	74,534.70	985,280.39	1,978.68	95.4	30.9
	Z250-3	1246.4	63.6	121.5	125.6	11,286,616.92	92,865.09	89,888.64	1,192,219.08	3,494.13	95.2	30.9
Z300	Z300-2	972.1	80.5	147.0	151.1	12,877,008.87	87,601.62	85,224.65	1,315,492.55	1,182.12	115.1	36.8
	Z300-2.5	1222.6	80.1	146.8	150.8	16,138,255.18	109,967.15	106,985.85	1,659,082.57	2,347.32	114.9	36.8
	Z300-3	1478.4	79.6	146.5	150.6	19,444,631.59	132,718.55	129,123.23	2,010,694.28	4,144.50	114.7	36.9
Z350	Z350-2	1117.3	92.5	172.0	176.1	20,052,154.64	116,607.88	113,850.07	1,895,935.95	1,358.64	134.0	41.2
	Z350-2.5	1405.0	92.0	171.7	175.9	25,144,471.97	146,425.66	142,965.23	2,391,408.10	2,697.52	133.8	41.3
	Z350-3	1698.8	91.5	171.5	175.6	30,313,993.80	176,782.55	172,607.52	2,898,857.18	4,762.36	133.6	41.3
	Z350-3.5	1994.4	91.0	171.2	175.4	35,487,018.19	207,245.27	202,357.41	3,420,482.33	7,685.24	133.4	41.4
	Z350-4	2288.5	90.5	171.0	175.1	40,591,617.33	237,397.78	231,800.66	3,927,248.50	11,602.80	133.2	41.4
Z400	Z400-2	1212.8	92.4	196.9	201.2	27,544,994.01	139,928.38	136,876.79	1,896,112.67	1,474.77	150.7	39.5
	Z400-2.5	1525.0	91.9	196.6	201.0	34,556,850.25	175,763.55	171,933.08	2,391,631.58	2,927.92	150.5	39.6
	Z400-3	1843.8	91.4	196.4	200.7	41,682,484.24	212,271.50	207,648.29	2,899,128.92	5,168.84	150.4	39.7
	Z400-3.5	2163.8	90.9	196.1	200.5	48,800,424.27	248,830.90	243,416.49	3,414,906.34	8,337.69	150.2	39.7
	Z400-4	2483.5	90.4	195.9	200.2	55,872,277.07	285,247.55	279,044.59	3,927,618.86	12,591.45	150.0	39.8

		Caracteristici geometrice ale secțiunii transversale eficace									
		TIP	Solicitarea de compresiune				Încovoiere după axa y-y cu talpa b_1 solicitată la compresiune				
			A_{ef} (mm ²)	$y_{Gef,c}$ (mm)	$z_{Gef,c1}$ (mm)	$z_{Gef,c2}$ (mm)	$z_{Gef,i1}$ (mm)	$z_{Gef,i2}$ (mm)	$I_{y,ef}$ (mm ⁴)	$W_{y,ef,1}$ (mm ³)	$W_{y,ef,2}$ (mm ³)
Z100	Z100-1.5	227.4	41.1	47.8	50.8	48.3	50.3	441,644.68	9,140.64	8,786.61	
	Z100-2	346.1	41.0	47.4	50.7	47.4	50.7	596,284.67	12,584.16	11,759.59	
Z120	Z120-1.5	227.6	41.1	57.5	61.1	58.4	60.2	676,538.89	11,582.02	11,244.33	
	Z120-2	350.8	40.9	57.3	60.8	57.3	60.8	917,821.81	16,012.64	15,102.86	
	Z120-2.5	479.6	40.8	56.7	60.9	57.0	60.6	1,140,352.68	20,011.84	18,812.70	
Z150	Z150-1.5	227.1	41.0	72.2	76.4	73.8	74.8	1,142,282.82	15,473.37	15,279.84	
	Z150-2	353.7	40.8	72.0	76.1	72.4	75.7	1,559,425.20	21,552.43	20,590.54	
	Z150-2.5	491.5	40.7	71.3	76.3	71.8	75.8	1,953,056.27	27,206.24	25,761.52	
Z180	Z180-1.5	252.2	53.3	89.2	89.3	95.8	82.8	1,999,210.61	20,865.06	24,155.61	
	Z180-2	412.0	53.7	87.2	90.8	88.8	89.3	2,959,837.94	33,337.51	33,142.66	
	Z180-2.5	579.6	53.5	87.0	90.6	87.5	90.1	3,763,252.30	42,988.23	41,786.73	
Z200	Z200-1.5	258.3	64.7	98.5	100.1	112.5	86.1	2,672,424.64	23,761.32	31,034.85	
	Z200-2	442.8	65.3	98.5	99.6	102.0	96.1	4,125,240.51	40,448.15	42,925.80	
	Z200-2.5	634.9	65.5	97.2	100.4	98.5	99.1	5,400,164.32	54,800.57	54,515.25	
Z250	Z250-1.5	255.4	64.9	123.5	125.1	144.7	103.9	4,326,065.57	29,894.78	41,648.75	
	Z250-2	439.2	65.2	123.3	124.8	132.2	115.9	6,714,974.41	50,802.46	57,931.73	
	Z250-2.5	633.5	65.4	121.8	125.8	124.7	122.9	9,060,224.81	72,666.32	73,709.86	
	Z250-3	843.7	65.2	121.6	125.5	122.6	124.5	11,127,714.78	90,741.25	89,401.69	
Z300	Z300-2	426.2	80.6	148.5	149.6	170.2	127.9	10,334,232.76	60,723.60	80,796.02	
	Z300-2.5	647.7	80.7	148.3	149.3	158.9	138.7	14,426,763.47	90,805.84	103,995.29	
	Z300-3	883.9	80.9	146.8	150.3	151.2	145.9	18,539,798.15	122,626.23	127,062.81	
Z350	Z350-2	419.7	92.9	173.9	174.2	208.2	139.9	14,767,181.70	70,927.00	105,564.73	
	Z350-2.5	650.2	92.4	173.6	174.0	194.3	153.3	20,965,609.34	107,908.25	136,753.99	
	Z350-3	914.1	92.5	173.0	174.1	183.9	163.2	27,450,485.90	149,278.27	168,189.17	
	Z350-3.5	1183.5	92.6	171.6	175.0	176.7	169.9	33,815,806.03	191,395.35	199,010.62	
	Z350-4	1464.6	92.4	171.3	174.8	174.1	172.0	39,405,131.00	226,332.22	229,103.67	
Z400	Z400-2	417.8	92.9	198.9	199.2	242.2	155.9	19,578,051.88	80,839.03	125,577.33	
	Z400-2.5	643.5	92.3	198.4	199.2	226.6	171.0	27,939,156.52	123,280.01	163,417.15	
	Z400-3	908.5	92.4	198.0	199.1	215.0	182.1	36,685,661.50	170,615.70	201,480.18	
	Z400-3.5	1178.7	92.6	196.4	200.2	206.9	189.7	45,278,252.40	218,867.23	238,652.55	
	Z400-4	1463.7	92.4	196.1	200.0	200.5	195.6	53,831,815.71	268,423.41	275,281.53	

TIP	Caracteristici geometrice ale secțiunii transversale eficace					Rezistențe după EN 1993.1.1			
	Încovoiere după axa y-y cu talpa b_2 solicitată la compresiune					Întindere	Compresie	Încovoiere	
	z_{Gef1} (mm)	z_{Gef2} (mm)	$I_{y,ef}$ (mm ⁴)	$W_{y,ef1}$ (mm ³)	$W_{y,ef2}$ (mm ³)	$N_{t,Rd}$ (kN)	$N_{c,Rd}$ (kN)	$M_{y,Rd}$ (kNm)	
Z100	Z100-1.5	51.1	47.5	448,888.72	8,785.88	9,452.69	102.72	79.59	3.08
	Z100-2	50.7	47.4	596,284.67	11,759.59	12,584.16	138.15	121.14	4.12
Z120	Z120-1.5	61.4	57.2	687,652.30	11,195.88	12,030.33	112.66	79.67	3.92
	Z120-2	60.9	57.2	920,079.50	15,115.85	16,079.26	151.52	122.78	5.29
	Z120-2.5	60.6	57.0	1,140,352.68	18,812.70	20,011.84	190.38	167.85	6.58
Z150	Z150-1.5	77.7	70.9	1,151,141.59	14,815.40	16,240.48	127.57	79.49	5.19
	Z150-2	76.1	72.0	1,570,469.44	20,646.56	21,804.34	171.58	123.79	7.21
	Z150-2.5	75.8	71.8	1,953,056.27	25,761.52	27,206.24	215.58	172.03	9.02
Z180	Z180-1.5	98.0	80.6	2,059,709.19	21,012.50	25,568.35	163.27	88.28	7.30
	Z180-2	91.8	86.3	2,999,391.28	32,679.26	34,752.48	219.91	144.19	11.44
	Z180-2.5	90.7	86.9	3,804,381.69	41,950.65	43,772.33	276.70	202.84	14.63
Z200	Z200-1.5	113.8	84.8	2,775,851.97	24,402.24	32,724.07	188.12	90.41	8.32
	Z200-2	104.3	93.8	4,217,548.50	40,423.50	44,984.34	253.33	154.97	14.15
	Z200-2.5	101.4	96.2	5,460,621.08	53,830.90	56,786.98	318.70	222.23	18.84
Z250	Z250-1.5	146.2	102.4	4,479,103.69	30,634.06	43,755.42	212.97	89.39	10.46
	Z250-2	134.9	113.2	6,846,928.22	50,771.91	60,467.41	286.76	153.71	17.77
	Z250-2.5	128.4	119.2	9,115,336.32	70,980.37	76,484.11	360.70	221.71	24.84
	Z250-3	125.9	121.2	11,237,677.01	89,266.79	92,711.44	436.25	295.28	31.24
Z300	Z300-2	172.1	125.9	10,590,000.65	61,516.57	84,086.83	340.24	149.18	21.25
	Z300-2.5	161.5	136.1	14,670,597.03	90,813.99	107,828.88	427.90	226.70	31.78
	Z300-3	154.8	142.3	18,669,713.98	120,620.68	131,181.59	517.45	309.36	42.22
Z350	Z350-2	209.9	138.2	15,134,463.64	72,105.55	109,513.83	391.05	146.89	24.82
	Z350-2.5	196.4	151.2	21,404,864.19	109,004.52	141,535.45	491.74	227.56	37.77
	Z350-3	186.7	160.4	27,834,811.04	149,096.69	173,522.55	594.59	319.94	52.18
	Z350-3.5	180.3	166.3	34,044,331.56	188,864.82	204,664.27	698.05	414.22	66.10
	Z350-4	177.2	168.9	39,779,300.66	224,488.31	235,519.66	800.98	512.60	78.57
Z400	Z400-2	243.9	154.2	20,067,411.58	82,288.69	130,118.59	424.47	146.21	28.29
	Z400-2.5	228.8	168.8	28,491,353.10	124,498.74	168,836.16	533.74	225.21	43.15
	Z400-3	217.9	179.2	37,182,559.24	170,601.56	207,549.52	645.34	317.97	59.71
	Z400-3.5	210.7	185.9	45,557,905.08	216,243.85	245,038.24	757.32	412.53	75.69
	Z400-4	204.4	191.7	54,146,854.77	264,888.30	282,476.71	869.23	512.30	92.71

1.3 Metoda de montaj

Pentru pane de acoperiș - se fixează vertical pe suport, cu "flanșa" superioară poziționată în direcția coamei acoperișului

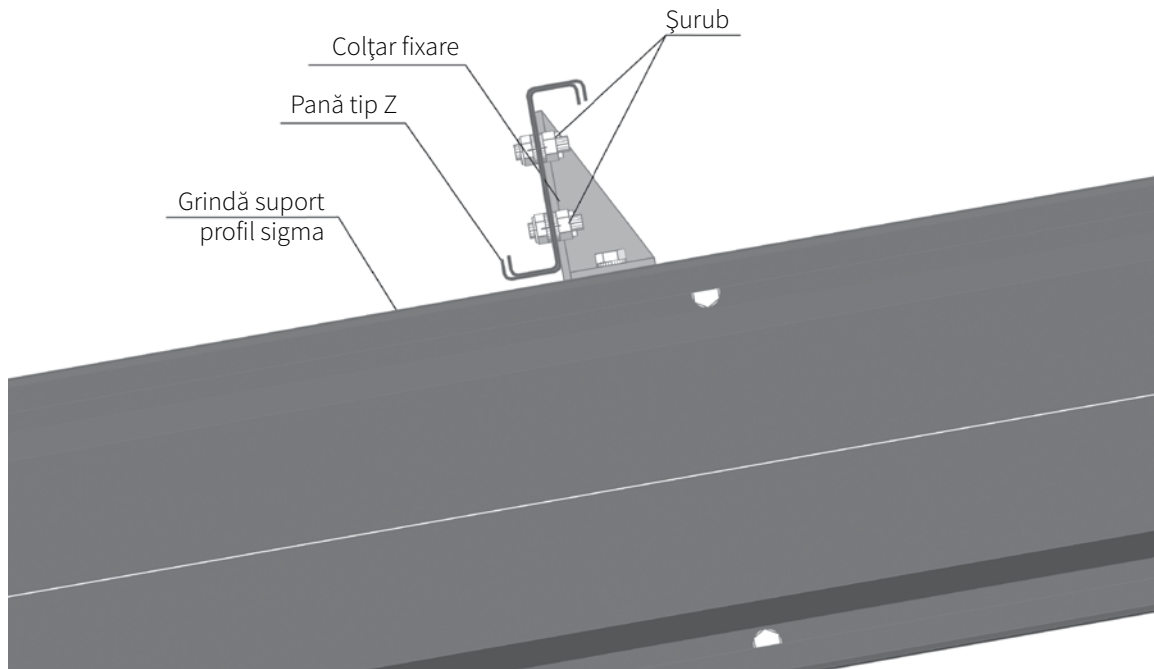

Înădirea profilelor tip Z

Recomandăm următoarele:

- lungimea suprapunerilor este $0.2L$ pentru reazemele curente (L este deschiderea grinzii) și $0.3L$ pentru primul reazem intermediar;
- în cazul utilizării unui profil suplimentar pe prima deschidere, acesta se dispune pe o lungime de $0.8L$

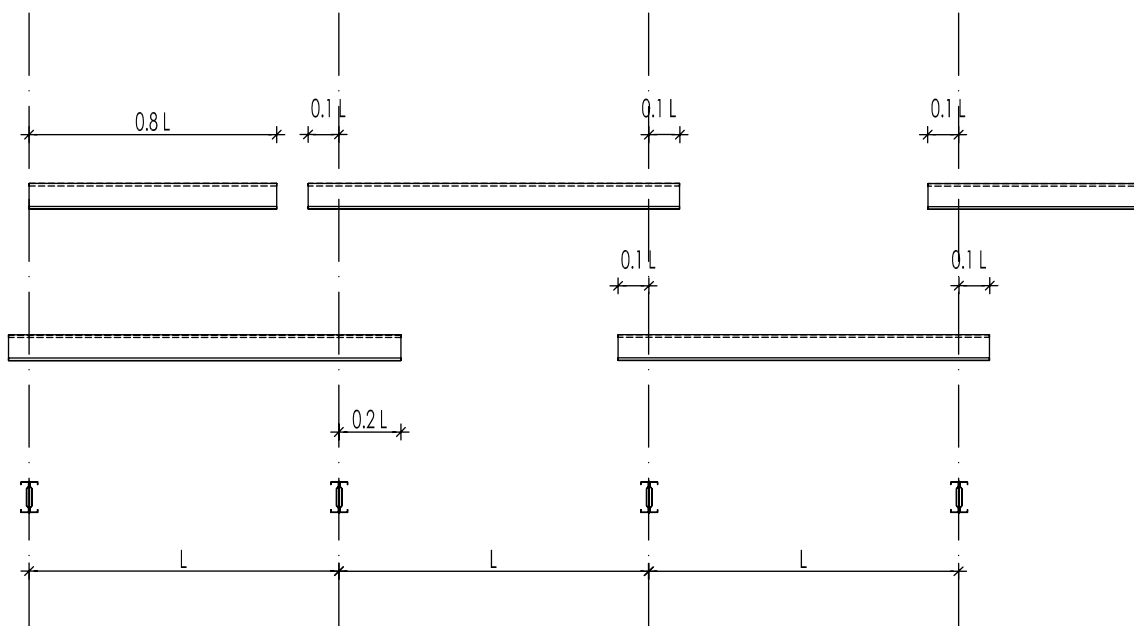

1.4 Încărcări statice

Profilele Z, folosite ca pane de acoperiș sunt analizate în varianta de grindă simplu rezemată sau grindă continuă cu mai multe deschideri, îmbinarea pe reazeme fiind realizată prin suprapunerea profilelor.

În modelul de calcul simplificat pentru determinarea capacității portante a profilelor s-au considerat următoarele ipoteze:

- pentru grinzile continue pe mai multe reazeme deschiderile sunt egale;
- reazemele sunt considerate în centrul de greutate al profilelor
- încărcarea este uniform distribuită pe toată lungimea profilului;
- lungimea suprapunerilor este de 0.2L pentru un reazem curent și de 0.3L pentru primul reazem intermediar;
- pentru diferitele sisteme statice și cazuri de încărcări tălpile superioare sunt considerate fixate rezultând astfel mai multe cazuri explicate ulterior;
- cu creșterea deschiderilor tălpile inferioare sunt considerate libere, fixate în mijlocul deschiderii cu o bară de stabilizare (3.50-5.50 m) sau fixate în 2 puncte la treimi cu bare de stabilizare (6.00-6.50 m) rezultând astfel mai multe cazuri explicate mai jos.

Sistem static cu

a. o bară de stabilizare

b. două bare stabilizatoare



Astfel s-au analizat 2 tipuri de sisteme statice, fiecare cu 5 cazuri de încărcare și variații ale fixărilor tălpilor care duc la o comportare mai eficientă și o îmbunătățire a capacității portante.

Sistem static nr. 1 (SS1): Grindă simplu rezemată;

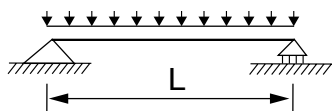

Sistem static nr. 5 (SS5): Grindă continuă peste trei sau mai multe deschideri, cu suprapunere pe reazem.

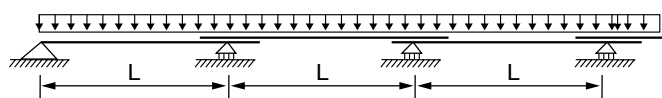

În funcție de tipul de încărcare considerat, gravitațională sau de sucțiune și de dispunerea tablei cutate, în tabel apar 3 cazuri de dimensionare în stare limită ultimă (ULS):

Caz 1: Tabla cutată se amplasează la ambele tălpi ale profilelor. Se determină capacitatea portantă din încărcarea gravitațională.

Caz 2: Tabla cutată se amplasează la talpa superioară a profilelor, iar capacitatea portantă se determină din încărcarea gravitațională.

Caz 3: Tabla cutată se amplasează la talpa superioară a profilelor, iar capacitatea portantă se determină din încărcarea din sucțiune.

Pentru dimensionarea la starea limită de serviciu (SLS) s-au considerat alte 2 cazuri care corespund unor valori limită admise pentru săgeți. Astfel s-au analizat cazurile:

Caz 4: S-a determinat încărcarea limită pentru o săgeată maximă admisă de $L/200$. Fixarea tălpilor s-a considerat doar la talpa superioară, acesta fiind cazul cel mai defavorabil.

Caz 5: S-a determinat încărcarea limită pentru o săgeată maximă admisă de $L/300$. Fixarea tălpilor s-a considerat doar la talpa superioară, acesta fiind cazul cel mai defavorabil.

Capacitate portantă* profile Z-SS1

Profil	Caz	Deschiderea [m]									
		3.00	3.50	4.00	4.50	5.00	5.50	6.00	6.50	7.00	7.50
Z100/1,5	1	2.86	2.08	1.60	1.24	1.01	0.82	0.68	0.58	0.50	0.43
	2	2.74	2.11	1.50	1.06	0.76	0.55	0.40	0.29	0.21	0.16
	3	0.98	0.61	0.39	0.26	0.19	0.14	0.11	0.09	0.08	0.07
	4	1.09	0.68	0.46	0.32	0.23	0.17	0.12	0.09	0.07	0.05
	5	0.72	0.45	0.29	0.20	0.14	0.10	0.07	0.05	0.04	0.02
Z100/2		3.00	3.50	4.00	4.50	5.00	5.50	6.00	6.50	7.00	7.50
	1	3.80	2.76	2.12	1.66	1.34	1.10	0.92	0.78	0.67	0.57
	2	3.68	2.76	2.01	1.44	1.04	0.75	0.55	0.41	0.30	0.23
	3	1.43	0.90	0.60	0.41	0.30	0.23	0.18	0.15	0.13	0.11
	4	1.49	0.95	0.63	0.44	0.32	0.23	0.17	0.13	0.10	0.07
5	0.98	0.61	0.41	0.28	0.20	0.14	0.10	0.08	0.05	0.04	
Z120/1.5		3.00	3.50	4.00	4.50	5.00	5.50	6.00	6.50	7.00	7.50
	1	3.67	2.66	2.05	1.61	1.30	1.06	0.90	0.75	0.65	0.56
	2	3.36	2.60	2.05	1.58	1.20	0.91	0.69	0.52	0.40	0.30
	3	1.32	0.82	0.53	0.36	0.26	0.19	0.15	0.12	0.10	0.09
	4	1.69	1.06	0.71	0.50	0.36	0.26	0.20	0.15	0.12	0.09
5	1.11	0.70	0.46	0.32	0.23	0.17	0.12	0.09	0.07	0.05	
Z120/2		3.00	3.50	4.00	4.50	5.00	5.50	6.00	6.50	7.00	7.50
	1	4.89	3.57	2.73	2.15	1.74	1.41	1.18	1.01	0.86	0.75
	2	4.53	3.50	2.75	2.13	1.62	1.23	0.94	0.72	0.55	0.42
	3	1.66	1.10	0.72	0.52	0.38	0.30	0.24	0.19	0.16	0.14
	4	2.30	1.47	0.98	0.69	0.50	0.37	0.28	0.21	0.17	0.13
5	1.53	0.96	0.65	0.50	0.32	0.23	0.17	0.13	0.10	0.07	

*Unitatea de măsură exprimată în kN/m

*Tabelele sunt informative și nu înlocuiesc analiza structurală necesară pentru proiectarea clădirii - conform EN 1993-1-3.

Capacitate portantă* profile Z-SS1

Profil	Caz	Deschiderea [m]									
		3.00	3.50	4.00	4.50	5.00	5.50	6.00	6.50	7.00	7.50
Z120/2.5	1	6.06	4.44	3.39	2.67	2.13	1.78	1.44	1.25	1.05	0.93
	2	5.65	4.35	3.39	2.64	2.02	1.55	1.20	0.92	0.72	0.56
	3	2.59	1.67	1.12	0.79	0.58	0.44	0.35	0.29	0.24	0.20
	4	2.94	1.87	1.26	0.89	0.64	0.48	0.35	0.28	0.22	0.17
	5	1.94	1.23	0.83	0.58	0.41	0.30	0.23	0.17	0.13	0.10
Z150/1.5		3.00	3.50	4.00	4.50	5.00	5.50	6.00	6.50	7.00	7.50
	1	4.68	3.48	2.66	2.09	1.69	1.39	1.16	0.98	0.84	0.73
	2	4.50	3.45	2.70	2.13	1.71	1.35	1.05	0.86	0.69	0.56
	3	1.30	0.82	0.55	0.40	0.30	0.23	0.18	0.15	0.13	0.11
	4	2.91	1.83	1.23	0.86	0.62	0.46	0.35	0.27	0.21	0.17
5	1.93	1.21	0.81	0.56	0.40	0.30	0.22	0.17	0.13	0.10	
Z150/2		3.00	3.50	4.00	4.50	5.00	5.50	6.00	6.50	7.00	7.50
	1	6.36	4.67	3.56	2.80	2.27	1.86	1.56	1.32	1.13	0.98
	2	6.04	4.61	3.61	2.85	2.29	1.86	1.42	1.15	0.94	0.77
	3	1.89	1.21	0.83	0.60	0.45	0.35	0.29	0.24	0.20	0.17
	4	3.96	3.23	1.68	1.18	0.86	0.64	0.49	0.38	0.30	0.24
5	2.62	1.65	1.11	0.77	0.56	0.41	0.31	0.24	0.19	0.14	
Z150/2.5		3.00	3.50	4.00	4.50	5.00	5.50	6.00	6.50	7.00	7.50
	1	7.97	5.85	4.46	3.51	2.84	2.33	1.95	1.65	1.42	1.23
	2	7.58	5.78	4.51	3.57	2.87	2.33	1.90	1.49	1.18	0.97
	3	2.93	1.90	1.30	0.94	0.71	0.55	0.45	0.37	0.31	0.26
	4	5.03	3.20	2.16	1.52	1.11	0.83	0.63	0.49	0.39	0.31
5	3.33	2.11	1.42	1.00	0.72	0.54	0.41	0.31	0.24	0.19	
Z180/1		3.00	3.50	4.00	4.50	5.00	5.50	6.00	6.50	7.00	7.50
	1	3.46	2.52	1.93	1.52	1.22	1.01	0.84	0.71	0.61	0.53
	2	3.50	2.31	1.81	1.45	1.19	0.99	0.84	0.61	0.52	0.45
	3	1.33	0.87	0.60	0.42	0.31	0.24	0.19	0.15	0.13	0.11
	4	3.33	2.09	1.39	0.97	0.70	0.52	0.40	0.31	0.24	0.19
5	2.21	1.38	0.92	0.64	0.46	0.34	0.25	0.19	0.15	0.12	

*Unitatea de măsură exprimată în kN/m

*Tabelele sunt informative și nu înlocuiesc analiza structurală necesară pentru proiectarea clădirii - conform EN 1993-1-3.

Capacitate portantă* profile Z-SS1

Profil	Caz	Deschiderea [m]									
		3.00	3.50	4.00	4.50	5.00	5.50	6.00	6.50	7.00	7.50
Z180/1.5	1	7.18	5.27	4.02	3.17	2.56	2.11	1.76	1.50	1.29	1.11
	2	6.10	4.71	3.78	3.10	2.57	1.81	1.51	1.27	1.08	0.92
	3	2.30	1.47	1.01	0.71	0.52	0.40	0.32	0.25	0.21	0.18
	4	5.08	3.20	2.14	1.50	1.08	0.81	0.62	0.48	0.38	0.30
	5	3.37	2.12	1.41	0.98	0.71	0.53	0.40	0.31	0.24	0.19
Z180/2		3.00	3.50	4.00	4.50	5.00	5.50	6.00	6.50	7.00	7.50
	1	9.55	7.03	5.37	4.23	3.42	2.81	2.36	2.00	1.72	1.49
	2	8.32	6.43	5.15	4.23	3.50	2.88	2.40	2.02	1.72	1.38
	3	3.29	2.11	1.45	1.03	0.76	0.59	0.46	0.38	0.31	0.27
	4	6.85	4.32	2.90	2.04	1.49	1.11	0.85	0.66	0.52	0.42
5	4.55	2.86	1.92	1.34	0.97	0.72	0.55	0.42	0.33	0.26	
Z180/2.5		3.00	3.50	4.00	4.50	5.00	5.50	6.00	6.50	7.00	7.50
	1	12.00	8.81	6.73	5.30	4.29	3.53	2.95	2.51	2.15	1.87
	2	10.44	8.07	6.47	5.29	4.39	3.61	3.01	2.53	2.15	1.78
	3	4.32	2.80	1.93	1.37	1.00	0.78	0.62	0.51	0.42	0.36
	4	8.65	4.68	3.68	2.59	1.89	1.42	1.09	0.85	0.68	0.54
5	5.74	3.62	2.43	1.71	1.24	0.93	0.71	0.55	0.43	0.34	
Z200/1.5		3.00	3.50	4.00	4.50	5.00	5.50	6.00	6.50	7.00	7.50
	1	8.38	6.15	4.70	3.70	2.99	2.46	2.06	1.75	1.50	1.30
	2	7.15	5.52	4.44	3.62	2.99	2.51	2.13	1.45	1.25	1.08
	3	3.22	2.12	1.47	1.05	0.77	0.59	0.46	0.37	0.30	0.25
	4	7.08	4.51	3.02	2.11	1.53	1.14	0.87	0.68	0.54	0.43
5	4.71	3.00	1.99	1.39	1.00	0.75	0.57	0.44	0.34	0.27	
Z200/2		3.00	3.50	4.00	4.50	5.00	5.50	6.00	6.50	7.00	7.50
	1	11.45	9.07	6.94	5.47	4.43	3.64	3.05	2.59	2.23	1.93
	2	10.00	7.75	6.26	5.18	4.35	3.72	3.15	2.66	2.28	1.96
	3	4.67	3.05	2.10	1.50	1.11	0.85	0.66	0.53	0.44	0.37
	4	9.65	6.08	4.07	2.85	2.07	1.55	1.19	0.93	0.74	0.56
5	6.42	4.03	2.69	1.88	1.36	1.02	0.77	0.60	0.47	0.37	
Z200/2.5		3.00	3.50	4.00	4.50	5.00	5.50	6.00	6.50	7.00	7.50
	1	15.50	11.40	8.70	6.86	5.55	4.57	3.83	3.25	2.79	2.42
	2	12.56	9.73	7.85	6.50	5.46	4.67	3.94	3.34	2.85	2.45
	3	6.17	4.03	2.75	1.95	1.45	1.11	0.87	0.72	0.59	0.50
	4	12.14	7.66	5.14	3.61	2.63	1.98	1.52	1.19	0.94	0.76
5	8.07	5.08	3.40	2.38	1.73	1.29	0.99	0.77	0.60	0.48	

*Unitatea de măsură exprimată în kN/m

*Tabelele sunt informative și nu înlocuiesc analiza structurală necesară pentru proiectarea clădirii - conform EN 1993-1-3.

Capacitate portantă* profile Z-SS1

Profil	Caz	Deschiderea [m]									
		3.00	3.50	4.00	4.50	5.00	5.50	6.00	6.50	7.00	7.50
Z250/1.5	1	10.53	7.67	5.89	4.64	3.74	3.10	2.59	2.19	1.89	1.64
	2	9.58	7.31	5.33	4.28	3.52	2.95	2.50	2.15	1.86	1.63
	3	4.34	2.87	1.99	1.43	1.05	0.80	0.63	0.50	0.41	0.34
	4	12.51	7.87	5.26	3.68	2.68	2.00	1.53	1.20	0.95	0.77
	5	8.32	5.23	3.49	2.44	1.77	1.32	1.01	0.78	0.62	0.49
Z250/2		3.00	3.50	4.00	4.50	5.00	5.50	6.00	6.50	7.00	7.50
	1	16.71	12.26	9.37	7.39	5.97	4.93	4.13	3.51	3.01	2.62
	2	13.56	10.38	8.28	6.78	5.65	4.79	4.10	3.52	3.05	2.67
	3	6.31	4.14	2.87	2.05	1.51	1.15	0.90	0.72	0.59	0.49
	4	16.80	10.58	7.09	4.97	3.62	2.71	2.08	1.63	1.30	1.05
5	11.18	7.02	4.70	3.29	2.39	1.78	1.36	1.06	0.84	0.67	
Z250/2.5		3.00	3.50	4.00	4.50	5.00	5.50	6.00	6.50	7.00	7.50
	1	21.69	15.93	12.17	9.60	7.76	6.40	5.36	4.56	3.92	3.40
	2	17.44	13.39	10.69	8.76	7.32	6.21	5.33	4.61	3.99	3.46
	3	8.35	5.47	3.78	2.70	1.99	1.52	1.19	0.95	0.78	0.65
	4	21.11	13.31	8.93	6.27	4.57	3.43	2.64	2.07	1.65	1.34
5	14.05	8.84	5.92	4.15	3.02	2.26	1.73	1.35	1.07	0.86	
Z250/3		3.00	3.50	4.00	4.50	5.00	5.50	6.00	6.50	7.00	7.50
	1	26.17	19.22	14.68	11.58	9.36	7.72	6.47	5.50	4.73	4.11
	2	21.07	16.15	12.91	10.57	8.82	7.48	6.42	5.56	4.81	4.18
	3	14.27	6.96	4.81	3.44	2.55	1.95	1.53	1.23	1.01	0.84
	4	25.51	16.12	10.83	7.62	5.57	4.19	3.22	2.53	2.02	1.64
5	16.98	10.71	7.18	5.05	3.68	2.76	2.12	1.66	1.32	1.06	
Z300/2		3.00	3.50	4.00	4.50	5.00	5.50	6.00	6.50	7.00	7.50
	1	21.93	15.99	12.31	9.70	7.82	6.47	5.42	4.59	3.96	3.44
	2	17.98	13.65	10.84	8.68	7.15	6.00	5.10	4.39	3.82	3.35
	3	10.83	5.08	5.55	2.43	1.76	1.31	1.00	0.79	0.63	0.51
	4	28.38	17.95	12.02	8.43	6.14	4.60	3.53	2.77	2.21	1.78
5	18.98	11.94	7.98	5.60	4.06	3.04	2.33	1.82	1.44	1.16	
Z300/2.5		3.00	3.50	4.00	4.50	5.00	5.50	6.00	6.50	7.00	7.50
	1	30.08	22.12	16.93	13.36	10.80	8.91	7.47	6.35	5.46	4.75
	2	23.38	17.75	14.14	11.58	9.66	8.22	7.08	6.16	5.40	4.77
	3	15.05	6.67	4.53	3.17	2.30	1.72	1.32	1.03	0.83	0.68
	4	35.73	22.55	15.12	10.61	7.73	5.80	4.46	3.39	2.78	2.26
5	23.85	15.00	10.03	7.03	5.12	3.83	2.93	2.30	1.83	1.47	

*Unitatea de măsură exprimată în kN/m

*Tabelele sunt informative și nu înlocuiesc analiza structurală necesară pentru proiectarea clădirii - conform EN 1993-1-3.

Capacitate portantă* profile Z-SS1

Profil	Caz	Deschiderea [m]									
		3.00	3.50	4.00	4.50	5.00	5.50	6.00	6.50	7.00	7.50
Z300/3	1	37.47	27.53	21.04	16.60	13.42	11.07	9.29	7.90	6.79	5.90
	2	28.66	21.84	17.41	14.26	11.94	10.17	8.77	7.64	6.70	5.93
	3	15.76	10.52	7.39	5.34	3.97	3.04	2.37	1.89	1.54	1.28
	4	43.22	27.25	18.27	12.84	9.36	7.03	5.41	4.25	3.40	2.75
	5	28.79	18.11	12.11	8.52	6.20	4.65	3.57	2.80	2.22	1.80
Z350/2		3.00	3.50	4.00	4.50	5.00	5.50	6.00	6.50	7.00	7.50
	1	26.85	18.84	14.48	11.43	9.21	7.62	6.39	5.42	4.67	4.06
	2	22.79	17.2	13.59	11.06	9.19	7.61	5.81	5.01	4.36	3.83
	3	12.4	8.47	6.06	4.46	3.36	2.58	2.03	1.63	1.33	1.1
	4	44.37	27.91	18.69	13.11	9.54	7.15	5.49	4.31	3.44	2.78
5	29.55	18.57	12.43	8.71	6.33	4.74	3.63	2.84	2.26	1.82	
Z350/2.5		3.00	3.50	4.00	4.50	5.00	5.50	6.00	6.50	7.00	7.50
	1	39.34	28.67	22.06	17.4	14.03	11.61	9.73	8.26	7.12	6.19
	2	29.76	22.5	17.83	14.55	12.14	10.32	8.89	7.73	6.74	5.92
	3	17.07	11.57	8.24	6.03	4.51	3.47	2.72	2.16	1.76	1.45
	4	55.65	35.03	23.46	16.47	11.99	9	6.92	5.43	4.33	3.51
5	37.07	23.33	15.6	10.94	7.95	5.96	4.57	3.58	2.85	2.3	
Z350/3		3.00	3.50	4.00	4.50	5.00	5.50	6.00	6.50	7.00	7.50
	1	49.02	36	27.54	21.72	17.57	14.5	12.16	10.35	8.9	7.74
	2	37.32	28.28	22.43	18.33	15.32	13.05	11.05	9.63	8.47	7.5
	3	21.39	14.49	10.31	7.53	5.64	4.34	3.4	2.71	2.2	1.82
	4	67.15	42.28	28.34	19.9	14.5	10.89	8.38	6.58	5.26	4.26
5	44.7	28.13	18.85	13.22	9.62	7.21	5.54	4.34	3.46	2.8	
Z350/3.5		3.00	3.50	4.00	4.50	5.00	5.50	6.00	6.50	7.00	7.50
	1	58.85	43.26	33.05	26.08	21.1	17.42	14.61	12.41	10.69	9.29
	2	43.73	33.11	26.28	21.46	17.94	15.28	13.2	11.51	10.13	8.98
	3	26.24	17.74	12.6	9.19	6.87	5.28	4.14	3.3	2.69	2.22
	4	78.61	49.55	33.23	23.36	17.04	12.8	9.86	7.75	6.2	5.03
5	52.39	32.98	22.1	15.52	11.3	8.48	6.52	5.11	4.08	3.3	
Z350/4		3.00	3.50	4.00	4.50	5.00	5.50	6.00	6.50	7.00	7.50
	1	67.5	49.55	37.89	29.9	24.2	19.95	16.74	14.24	12.25	10.65
	2	50.05	37.91	30.12	24.58	20.56	17.5	15.12	13.19	11.61	10.29
	3	31.43	21.19	15.03	10.96	8.18	6.29	4.94	3.94	3.21	2.65
	4	90.12	56.82	38.14	26.82	19.58	14.73	11.35	8.93	7.15	5.81
5	60	37.8	25.36	17.82	12.99	9.76	7.51	5.89	4.71	3.81	

*Unitatea de măsură exprimată în kN/m

*Tabelele sunt informative și nu înlocuiesc analiza structurală necesară pentru proiectarea clădirii - conform EN 1993-1-3.

Capacitate portantă* profile Z-SS1

Profil	Caz	Deschiderea [m]									
		3.00	3.50	4.00	4.50	5.00	5.50	6.00	6.50	7.00	7.50
Z400/2	1	28.63	21.09	16.22	12.80	10.32	8.54	7.16	6.07	5.23	4.54
	2	27.53	20.70	16.06	12.70	10.28	8.51	6.48	5.58	4.85	4.26
	3	14.52	9.95	7.15	5.27	3.97	3.07	2.41	1.93	1.57	1.30
	4	62.20	39.14	26.21	18.39	13.39	10.04	7.72	6.06	4.83	3.92
	5	41.44	25.31	17.44	12.23	8.89	6.66	5.11	4.01	3.19	2.58
Z400/2.5		3.00	3.50	4.00	4.50	5.00	5.50	6.00	6.50	7.00	7.50
	1	43.78	31.91	24.55	19.37	15.62	12.93	10.84	9.21	7.94	6.90
	2	35.98	27.10	21.42	17.39	13.90	11.65	9.93	8.56	7.45	6.54
	3	20.03	13.64	9.73	7.12	5.34	4.11	3.22	2.57	2.08	1.71
	4	78.06	49.13	32.90	23.10	16.82	12.63	9.71	7.62	6.09	4.94
5	52.00	31.76	21.89	15.36	11.17	8.37	6.43	5.04	4.02	3.25	
Z400/3		3.00	3.50	4.00	4.50	5.00	5.50	6.00	6.50	7.00	7.50
	1	56.25	41.00	31.55	24.89	20.07	16.61	13.93	11.83	10.20	8.87
	2	44.62	33.62	26.56	21.57	17.93	15.12	12.86	11.08	9.64	8.47
	3	25.17	17.09	12.18	8.91	6.68	5.14	4.02	3.21	2.60	2.14
	4	94.18	59.29	39.74	27.90	20.34	15.27	11.75	9.23	7.38	5.99
5	62.74	38.33	26.42	18.55	13.51	10.13	7.79	6.11	4.87	3.94	
Z400/3.5		3.00	3.50	4.00	4.50	5.00	5.50	6.00	6.50	7.00	7.50
	1	70.45	51.70	39.56	31.21	25.25	20.85	17.49	14.88	12.80	11.13
	2	54.03	40.87	32.31	26.32	21.92	18.62	15.76	13.69	12.02	10.63
	3	30.87	20.91	14.88	10.86	8.13	6.25	4.89	3.90	3.17	2.61
	4	110.30	69.51	46.58	32.73	23.87	17.94	13.82	10.86	8.69	7.05
5	73.48	46.26	31.00	21.77	15.85	11.90	9.15	7.18	5.73	4.65	
Z400/4		3.00	3.50	4.00	4.50	5.00	5.50	6.00	6.50	7.00	7.50
	1	82.48	60.53	46.32	36.54	29.56	24.41	20.48	17.42	14.99	13.03
	2	61.92	46.84	37.03	30.16	25.12	21.32	18.36	15.96	14.01	12.4
	3	36.96	24.97	17.73	12.93	9.66	7.43	5.82	4.63	3.77	3.11
	4	126.35	79.66	53.44	37.58	27.42	20.62	15.89	12.50	10.01	8.14
5	84.17	53.04	35.55	24.98	18.21	13.68	10.53	8.27	6.61	5.36	

*Unitatea de măsură exprimată în kN/m

*Tabelele sunt informative și nu înlocuiesc analiza structurală necesară pentru proiectarea clădirii - conform EN 1993-1-3.

Capacitate portantă* profile Z-SS5

Profil	Caz	Deschiderea [m]									
		3.00	3.50	4.00	4.50	5.00	5.50	6.00	6.50	7.00	7.50
Z120/(2+2)	1	7.40	5.60	4.20	3.55	2.85	2.35	1.98	1.68	1.44	1.25
	2	3.75	2.60	2.75	2.05	1.55	1.23	1.13	1.00	0.80	0.67
	3	4.00	2.55	2.40	1.70	1.25	0.97	0.97	0.77	0.62	0.51
	4	5.30	3.35	2.80	1.95	1.43	1.06	0.80	0.63	0.50	0.40
	5	3.55	2.20	1.85	1.30	0.94	0.70	0.53	0.41	0.32	0.25
Z120/(2+1,5)		3.00	3.50	4.00	4.50	5.00	5.50	6.00	6.50	7.00	7.50
	1	7.35	5.80	4.40	3.47	2.80	2.32	1.95	1.65	1.42	1.23
	2	2.90	1.88	2.60	1.91	1.45	1.12	1.07	0.85	0.70	0.57
	3	3.95	2.55	2.37	1.70	1.28	0.97	0.96	0.77	0.62	0.51
	4	5.25	3.32	2.92	1.93	1.40	1.05	0.80	0.62	0.47	0.39
5	3.50	2.20	1.84	1.28	0.92	0.68	0.52	0.40	0.31	0.25	
Z120/(2+1)		3.00	3.50	4.00	4.50	5.00	5.50	6.00	6.50	7.00	7.50
	1	6.20	4.40	3.35	2.70	2.18	1.81	1.50	1.28	1.10	0.95
	2	1.80	1.17	1.92	1.45	1.09	0.84	0.82	0.65	0.52	0.42
	3	3.30	2.20	1.99	1.48	1.11	0.86	0.82	0.66	0.54	0.44
	4	5.15	3.29	2.75	1.92	1.39	1.04	0.79	0.61	0.48	0.38
5	3.45	2.17	1.82	1.25	0.91	0.68	0.51	0.39	0.31	0.24	
Z120/(2,5+2,5)		3.00	3.50	4.00	4.50	5.00	5.50	6.00	6.50	7.00	7.50
	1	9.30	7.35	5.60	4.45	3.60	2.95	2.50	2.10	1.80	1.55
	2	5.30	3.70	3.70	2.75	2.15	1.70	1.50	1.35	1.10	0.90
	3	5.50	3.60	3.10	2.30	1.70	1.30	1.25	1.00	0.80	0.70
	4	6.75	4.30	3.50	2.50	1.80	1.30	1.00	0.80	0.63	0.50
5	4.50	2.85	2.30	1.60	1.15	0.85	0.65	0.50	0.40	0.30	
Z120/(2,5+2)		3.00	3.50	4.00	4.50	5.00	5.50	6.00	6.50	7.00	7.50
	1	9.20	7.30	5.60	4.40	3.55	2.95	2.45	2.10	1.80	1.55
	2	4.45	3.10	3.45	2.55	2.00	1.55	1.40	1.20	1.00	0.80
	3	5.45	3.55	3.05	2.25	1.70	1.25	1.25	1.00	0.80	0.65
	4	6.65	4.25	3.45	2.40	1.75	1.30	1.00	0.75	0.60	0.50
5	4.45	2.80	2.30	1.60	1.15	0.85	0.65	0.50	0.40	0.30	
Z120/(2,5+1,5)		3.00	3.50	4.00	4.50	5.00	5.50	6.00	6.50	7.00	7.50
	1	9.00	6.60	5.00	4.00	3.20	2.68	2.23	1.89	1.63	1.42
	2	3.20	2.10	3.15	2.30	1.75	1.38	1.33	1.08	0.87	0.72
	3	5.00	3.40	3.00	2.15	1.60	1.25	1.23	0.99	0.81	0.67
	4	6.60	4.10	3.40	2.35	1.73	1.28	0.98	0.76	0.60	0.48
5	4.40	2.75	2.25	1.55	1.14	0.83	0.64	0.49	0.38	0.30	

*Unitatea de măsură exprimată în kN/m

*Tabelele sunt informative și nu înlocuiesc analiza structurală necesară pentru proiectarea clădirii - conform EN 1993-1-3.

Capacitate portantă* profile Z-SS5

Profil	Caz	Deschiderea [m]									
		3.00	3.50	4.00	4.50	5.00	5.50	6.00	6.50	7.00	7.50
Z120/(2,5+1)	1	6.10	4.45	3.35	2.73	2.20	1.80	1.50	1.30	1.11	0.96
	2	2.03	1.32	2.00	1.50	1.15	0.80	0.83	0.66	0.55	0.43
	3	3.68	2.45	2.25	1.71	1.29	1.00	0.92	0.78	0.64	0.52
	4	6.60	4.80	3.45	2.40	1.73	1.23	0.98	0.76	0.60	0.47
	5	4.40	2.75	2.27	1.55	1.10	0.84	0.64	0.49	0.38	0.30
Z120/(1+1)		3.00	3.50	4.00	4.50	5.00	5.50	6.00	6.50	7.00	7.50
	1	3.20	2.32	1.72	1.38	1.11	0.90	0.76	0.65	0.55	0.48
	2	1.05	0.67	1.10	0.82	0.61	0.46	0.44	0.33	0.27	0.22
	3	1.42	0.92	0.95	0.68	0.50	0.38	0.41	0.33	0.27	0.22
	4	2.55	1.62	1.41	0.89	0.71	0.53	0.41	0.31	0.25	0.20
Z120/(1,5+1,5)		3.00	3.50	4.00	4.50	5.00	5.50	6.00	6.50	7.00	7.50
	1	5.55	4.10	3.10	2.65	2.10	1.80	1.50	1.30	1.10	0.95
	2	2.00	1.35	2.00	1.45	1.10	0.85	0.80	0.65	0.55	0.40
	3	2.35	1.55	1.65	1.15	0.85	0.65	0.70	0.55	0.45	0.40
	4	3.95	2.50	2.10	1.50	1.10	0.80	0.65	0.50	0.40	0.30
Z120/(1,5+1)		3.00	3.50	4.00	4.50	5.00	5.50	6.00	6.50	7.00	7.50
	1	5.50	4.10	3.10	2.45	1.90	1.70	1.45	1.20	1.00	0.90
	2	1.58	1.00	1.75	1.30	0.95	0.75	0.75	0.60	0.50	0.40
	3	2.33	1.51	1.60	1.15	0.85	0.65	0.70	0.55	0.40	0.40
	4	3.85	2.43	2.05	1.45	1.05	0.80	0.65	0.50	0.40	0.30
Z150/(2+2)		3.00	3.50	4.00	4.50	5.00	5.50	6.00	6.50	7.00	7.50
	1	10.70	8.25	6.35	5.00	4.05	3.30	2.80	2.35	2.00	1.75
	2	4.55	3.05	3.85	2.80	2.10	1.60	1.55	1.25	1.00	0.80
	3	4.70	3.10	3.35	2.40	1.75	1.30	1.30	1.05	0.85	0.65
	4	9.20	5.80	4.80	3.35	2.45	1.80	1.45	1.10	0.85	0.70
Z150/(2+1,5)		3.00	3.50	4.00	4.50	5.00	5.50	6.00	6.50	7.00	7.50
	1	10.50	8.15	6.05	4.90	3.95	3.25	2.70	2.30	2.00	1.75
	2	3.55	2.25	3.55	2.55	1.95	1.45	1.45	1.15	0.95	0.75
	3	4.65	3.00	3.30	2.35	1.75	1.30	1.30	1.00	0.85	0.65
	4	9.00	5.70	4.75	3.30	2.40	1.80	1.40	1.05	0.85	0.65
Z150/(2+1,5)		3.00	3.50	4.00	4.50	5.00	5.50	6.00	6.50	7.00	7.50
	1	6.00	3.80	3.15	2.20	1.55	1.20	0.90	0.70	0.55	0.40

*Unitatea de măsură exprimată în kN/m

*Tabelele sunt informative și nu înlocuiesc analiza structurală necesară pentru proiectarea clădirii - conform EN 1993-1-3.

Capacitate portantă* profile Z-SS5

Profil	Caz	Deschiderea [m]									
		3.00	3.50	4.00	4.50	5.00	5.50	6.00	6.50	7.00	7.50
Z150/(2+1)	1	8.10	5.75	4.35	3.55	2.90	2.40	1.95	1.65	1.45	1.25
	2	2.30	1.45	2.50	1.80	1.35	1.05	1.10	0.85	0.70	0.55
	3	4.60	3.00	2.65	1.90	1.40	1.05	1.10	0.85	0.70	0.55
	4	8.95	5.60	4.70	3.30	2.35	1.75	1.35	1.05	0.80	0.65
	5	5.95	3.75	3.10	2.15	1.55	1.15	0.90	0.65	0.50	0.40
Z150/(2,5+2,5)		3.00	3.50	4.00	4.50	5.00	5.50	6.00	6.50	7.00	7.50
	1	13.45	10.30	7.90	6.20	5.05	4.15	3.45	2.95	2.55	2.20
	2	6.40	4.40	4.95	3.65	2.80	2.15	2.00	1.60	1.35	1.10
	3	7.15	4.65	4.25	3.10	2.25	1.70	1.70	1.35	1.10	0.90
	4	11.55	7.35	6.00	4.20	3.05	2.25	1.75	1.35	1.05	0.85
5	7.70	4.90	4.00	2.75	2.00	1.50	1.15	0.85	0.70	0.55	
Z150/(2,5+2)		3.00	3.50	4.00	4.50	5.00	5.50	6.00	6.50	7.00	7.50
	1	13.50	10.20	7.75	6.15	4.95	4.05	3.40	2.90	2.50	2.15
	2	5.35	3.60	4.75	3.40	2.60	2.00	1.95	1.55	1.25	1.00
	3	7.05	4.60	4.20	3.05	2.25	1.70	1.65	1.30	1.05	0.85
	4	11.40	7.25	5.90	4.15	3.00	2.25	1.70	1.35	1.05	0.85
5	7.60	4.80	3.90	2.75	1.95	1.45	1.10	0.85	0.65	0.55	
Z150/(2,5+1,5)		3.00	3.50	4.00	4.50	5.00	5.50	6.00	6.50	7.00	7.50
	1	12.55	9.25	6.95	5.55	4.45	3.70	3.10	2.65	2.25	2.00
	2	3.90	2.55	4.15	3.00	2.25	1.75	1.75	1.40	1.15	0.90
	3	6.90	4.55	4.00	2.90	2.15	1.65	1.60	1.25	1.05	0.85
	4	11.30	7.20	5.90	4.10	2.95	2.20	1.75	1.35	1.05	0.85
5	7.50	4.75	3.90	2.70	1.95	1.45	1.10	0.85	0.65	0.55	
Z150/(2,5+1)		3.00	3.50	4.00	4.50	5.00	5.50	6.00	6.50	7.00	7.50
	1	8.10	5.85	4.40	3.55	2.90	2.35	2.00	1.70	1.45	1.25
	2	2.45	1.65	2.60	1.90	1.40	1.05	1.15	0.90	0.70	0.55
	3	5.05	3.35	2.90	2.15	1.50	1.25	1.25	0.95	0.80	0.65
	4	11.30	7.20	5.90	4.10	3.00	2.20	1.70	1.30	1.05	0.80
5	7.50	4.75	3.90	2.70	1.95	1.45	1.10	0.85	0.65	0.50	
Z150/(1+1)		3.00	3.50	4.00	4.50	5.00	5.50	6.00	6.50	7.00	7.50
	1	4.15	3.55	2.30	1.80	1.45	1.20	1.00	0.85	0.70	0.64
	2	1.35	0.85	1.45	1.05	0.75	0.55	0.55	0.45	0.35	0.29
	3	1.95	1.25	1.25	0.90	0.65	0.50	0.50	0.40	0.35	0.28
	4	4.45	2.80	2.40	1.65	1.20	0.90	0.70	0.55	0.40	0.35
5	2.95	1.85	1.55	1.10	0.80	0.60	0.45	0.35	0.28	0.22	

*Unitatea de măsură exprimată în kN/m

*Tabelele sunt informative și nu înlocuiesc analiza structurală necesară pentru proiectarea clădirii - conform EN 1993-1-3.

Capacitate portantă* profile Z-SS5

Profil	Caz	Deschiderea [m]									
		3.00	3.50	4.00	4.50	5.00	5.50	6.00	6.50	7.00	7.50
Z150/(1,5+1,5)	1	7.40	5.70	4.10	3.20	2.60	2.10	1.75	1.52	1.30	1.10
	2	2.45	1.60	2.55	1.85	1.40	1.05	1.05	0.85	0.68	0.54
	3	3.25	2.10	2.05	1.50	1.10	0.80	0.92	0.72	0.58	0.48
	4	6.80	4.25	3.55	2.50	1.80	1.35	1.05	0.82	0.65	0.52
	5	4.55	2.45	2.40	1.65	1.20	0.90	0.70	0.54	0.42	0.34
Z150/(1,5+1)		3.00	3.50	4.00	4.50	5.00	5.50	6.00	6.50	7.00	7.50
	1	7.70	5.50	4.10	3.30	2.65	2.20	1.85	1.56	1.34	1.17
	2	2.00	1.25	2.35	1.65	1.20	0.90	1.00	0.79	0.62	0.49
	3	3.20	2.05	2.10	1.45	1.10	0.83	0.90	0.70	0.56	0.45
	4	6.60	4.20	3.55	2.45	1.80	1.34	1.03	0.80	0.64	0.51
5	4.45	2.75	2.35	1.60	1.15	0.88	0.68	0.52	0.41	0.33	
Z180/(2+2)		3.00	3.50	4.00	4.50	5.00	5.50	6.00	6.50	7.00	7.50
	1	15.95	11.80	8.95	7.50	6.05	5.00	4.20	3.55	3.05	2.65
	2	6.65	4.35	6.50	4.85	3.75	2.85	2.70	2.20	1.80	1.50
	3	7.70	5.15	5.45	4.00	2.95	2.25	2.50	2.00	1.60	1.35
	4	16.00	10.10	8.80	6.20	4.50	3.35	2.60	2.05	1.60	1.30
5	10.65	6.70	5.85	4.10	3.00	2.25	1.70	1.35	1.05	0.85	
Z180/(2+1,5)		3.00	3.50	4.00	4.50	5.00	5.50	6.00	6.50	7.00	7.50
	1	15.85	11.60	8.85	7.40	6.00	4.95	4.15	3.55	3.05	2.65
	2	6.15	3.95	6.25	4.65	3.55	2.70	2.60	2.15	1.75	1.45
	3	7.60	5.05	5.40	3.95	2.95	2.25	2.45	1.95	1.60	1.30
	4	15.70	9.90	8.70	6.10	4.40	3.30	2.55	2.00	1.60	1.25
5	10.45	6.60	5.75	4.05	2.95	2.20	1.70	1.30	1.05	0.85	
Z180/(2+1)		3.00	3.50	4.00	4.50	5.00	5.50	6.00	6.50	7.00	7.50
	1	9.45	8.15	6.70	5.40	4.45	3.70	3.10	2.60	2.30	1.95
	2	4.15	2.65	4.05	3.00	2.30	1.80	1.85	1.50	1.20	1.00
	3	7.00	4.70	4.20	3.15	2.40	1.85	1.85	1.50	1.20	1.00
	4	15.55	9.80	8.60	6.05	4.40	3.25	2.55	2.00	1.60	1.25
5	10.35	5.60	5.70	4.00	2.90	2.15	1.65	1.30	1.05	0.80	
Z180/(2,5+2,5)		3.00	3.50	4.00	4.50	5.00	5.50	6.00	6.50	7.00	7.50
	1	19.95	15.55	11.90	9.40	7.60	6.25	5.25	4.50	3.85	3.35
	2	10.60	7.15	8.30	6.20	4.75	3.75	3.50	2.85	2.30	1.95
	3	11.10	7.15	7.70	5.60	4.25	3.25	3.15	2.50	2.05	1.70
	4	20.10	12.70	11.00	7.70	5.60	4.20	3.25	2.55	2.00	1.65
5	13.40	7.25	7.35	5.10	3.70	2.80	2.15	1.65	1.35	1.05	

*Unitatea de măsură exprimată în kN/m

*Tabelele sunt informative și nu înlocuiesc analiza structurală necesară pentru proiectarea clădirii - conform EN 1993-1-3.

Capacitate portantă* profile Z-SS5

Profil	Caz	Deschiderea [m]									
		3.00	3.50	4.00	4.50	5.00	5.50	6.00	6.50	7.00	7.50
Z180/(2,5+2)	1	19.85	15.45	11.80	9.35	7.55	6.15	5.20	4.45	3.80	3.30
	2	9.25	6.15	8.00	6.00	4.60	3.55	3.35	2.75	2.20	1.85
	3	10.75	7.05	7.65	5.55	4.20	3.20	3.10	2.50	2.05	1.65
	4	19.80	12.50	10.90	7.60	5.55	4.15	3.20	2.50	2.00	1.60
	5	13.20	8.35	7.20	5.05	3.65	2.75	2.10	1.65	1.30	1.05
Z180/(2,5+1,5)		3.00	3.50	4.00	4.50	5.00	5.50	6.00	6.50	7.00	7.50
	1	19.35	14.20	10.90	8.55	6.95	5.70	4.80	4.05	3.50	3.05
	2	7.10	4.50	7.45	5.50	4.15	3.20	3.20	2.55	2.05	1.70
	3	10.55	6.80	7.30	5.40	4.05	3.10	3.10	2.45	2.00	1.60
	4	19.60	12.40	10.80	7.55	5.50	4.10	3.20	2.50	1.95	1.60
5	13.05	8.25	7.15	5.00	3.65	2.70	2.10	1.60	1.30	1.05	
Z180/(2,5+1)		3.00	3.50	4.00	4.50	5.00	5.50	6.00	6.50	7.00	7.50
	1	9.45	8.15	6.70	5.45	4.45	3.70	3.10	2.60	2.25	1.95
	2	4.45	2.90	4.20	3.15	2.35	1.85	1.90	1.55	1.25	1.05
	3	7.35	5.05	4.50	3.40	2.60	2.00	2.00	1.60	1.30	1.10
	4	19.60	12.40	10.80	7.55	5.50	4.10	3.20	2.45	1.95	1.60
5	13.05	8.25	7.15	5.00	3.65	2.70	2.10	1.60	1.30	1.05	
Z180/(1+1)		3.00	3.50	4.00	4.50	5.00	5.50	6.00	6.50	7.00	7.50
	1	6.20	4.55	3.45	2.75	2.20	1.80	1.50	1.30	1.15	0.95
	2	2.45	1.60	2.25	1.70	1.30	1.00	1.00	0.80	0.65	0.55
	3	3.05	2.05	2.05	1.50	1.15	0.90	0.90	0.75	0.60	0.50
	4	7.90	4.95	4.40	3.05	2.25	1.70	1.30	1.00	0.80	0.65
5	5.25	3.30	2.90	2.05	1.50	1.10	0.85	0.65	0.55	0.45	
Z180/(1,5+1,5)		3.00	3.50	4.00	4.50	5.00	5.50	6.00	6.50	7.00	7.50
	1	12.10	8.90	6.80	5.45	4.40	3.65	3.05	2.65	2.25	1.95
	2	4.40	2.85	4.20	3.15	2.40	1.85	1.85	1.50	1.20	0.95
	3	5.35	3.60	3.70	2.75	2.05	1.55	1.65	1.35	1.10	0.90
	4	11.90	7.50	6.60	4.65	3.35	2.50	1.95	1.55	1.20	0.95
5	7.90	5.00	4.40	3.10	2.25	1.70	1.30	1.00	0.80	0.65	
Z180/(1,5+1)		3.00	3.50	4.00	4.50	5.00	5.50	6.00	6.50	7.00	7.50
	1	9.50	8.20	6.75	5.35	4.30	3.55	2.75	2.55	2.00	1.90
	2	3.90	2.45	3.90	2.90	2.20	1.65	1.75	1.40	1.15	0.90
	3	5.30	3.55	3.65	2.70	2.00	1.55	1.60	1.30	1.05	0.85
	4	11.65	7.35	6.50	4.55	3.30	2.45	1.90	1.50	1.15	0.95
5	7.75	4.85	4.30	3.00	2.20	1.60	1.25	0.95	0.80	0.65	

*Unitatea de măsură exprimată în kN/m

*Tabelele sunt informative și nu înlocuiesc analiza structurală necesară pentru proiectarea clădirii - conform EN 1993-1-3.

Capacitate portantă* profile Z-SS5

Profil	Caz	Deschiderea [m]									
		3.00	3.50	4.00	4.50	5.00	5.50	6.00	6.50	7.00	7.50
Z200/(2+2)	1	20.38	15.08	11.42	9.70	7.84	6.48	5.44	4.63	3.98	3.46
	2	9.32	6.19	8.52	6.44	4.95	3.92	3.74	3.06	2.53	2.11
	3	10.29	7.00	7.52	5.60	4.21	3.31	3.41	2.76	2.29	1.90
	4	22.50	14.19	12.83	8.98	6.54	4.90	3.79	2.97	2.37	1.91
	5	15.00	9.43	8.53	5.97	4.34	3.25	2.51	1.96	1.56	1.26
Z200/(2+1,5)		3.00	3.50	4.00	4.50	5.00	5.50	6.00	6.50	7.00	7.50
	1	20.17	14.98	11.30	9.62	7.77	6.42	5.38	4.58	3.94	3.43
	2	8.62	5.61	8.27	6.22	4.75	3.74	3.65	2.97	2.45	2.04
	3	10.15	6.90	7.46	5.51	4.18	3.28	3.38	2.74	2.27	1.89
	4	22.13	13.96	12.64	8.85	6.43	4.82	3.73	2.92	2.32	1.88
5	14.74	9.28	8.40	5.88	4.27	3.19	2.47	1.93	1.53	1.23	
Z200/(2,5+2,5)		3.00	3.50	4.00	4.50	5.00	5.50	6.00	6.50	7.00	7.50
	1	25.50	19.00	14.85	12.15	9.85	8.10	6.80	5.80	5.00	4.35
	2	12.70	8.50	11.45	8.75	6.70	5.25	4.85	4.00	3.30	2.75
	3	13.65	9.30	11.00	8.10	6.15	4.85	4.55	3.70	3.05	2.55
	4	28.26	17.85	16.00	11.20	8.15	6.10	4.70	3.70	2.95	2.35
5	18.82	11.85	10.65	7.45	5.40	4.05	3.10	2.45	1.95	1.55	
Z200/(2,5+2)		3.00	3.50	4.00	4.50	5.00	5.50	6.00	6.50	7.00	7.50
	1	25.30	18.75	14.60	12.05	9.75	8.05	6.75	5.75	4.95	4.30
	2	12.25	8.10	11.20	8.50	6.60	5.15	4.75	3.95	3.20	2.65
	3	13.50	9.20	10.90	8.00	6.20	4.80	4.50	3.70	3.05	2.50
	4	27.90	17.60	15.80	11.10	8.05	6.05	4.65	3.65	2.90	2.35
5	18.55	11.70	10.50	7.35	5.35	4.00	3.10	2.40	1.90	1.55	
Z200/(2,5+1,5)		3.00	3.50	4.00	4.50	5.00	5.50	6.00	6.50	7.00	7.50
	1	22.10	18.30	14.00	11.05	8.90	7.35	6.20	5.25	4.50	3.95
	2	10.35	6.65	10.20	7.70	5.85	4.55	4.45	3.60	2.95	2.45
	3	13.40	8.50	10.35	7.75	5.90	4.55	4.30	3.45	2.80	2.30
	4	27.65	16.55	15.65	11.00	8.00	6.00	4.60	3.60	2.85	2.30
5	18.40	11.00	10.40	7.30	5.30	3.95	3.05	2.40	1.90	1.50	
Z200/(1,5+1,5)		3.00	3.50	4.00	4.50	5.00	5.50	6.00	6.50	7.00	7.50
	1	14.85	10.90	8.35	6.60	5.30	4.40	3.70	3.15	2.70	2.35
	2	6.25	4.10	5.65	4.30	3.30	2.60	2.40	1.95	1.60	1.30
	3	7.05	4.80	5.00	3.75	2.90	2.25	2.30	1.90	1.55	1.30
	4	16.85	10.60	9.60	6.75	4.90	3.65	2.85	2.20	1.90	1.40
5	11.20	7.05	6.40	4.45	3.25	2.40	1.85	1.45	1.25	0.95	

*Unitatea de măsură exprimată în kN/m

*Tabelele sunt informative și nu înlocuiesc analiza structurală necesară pentru proiectarea clădirii - conform EN 1993-1-3.

Capacitate portantă* profile Z-SS5

Profil	Caz	Deschiderea [m]									
		3.00	3.50	4.00	4.50	5.00	5.50	6.00	6.50	7.00	7.50
Z250/(3+3)	1	43.95	33.88	25.90	20.47	16.55	13.65	11.48	9.77	8.40	7.30
	2	21.55	14.37	19.83	14.83	11.37	9.05	8.30	6.81	5.61	4.71
	3	23.58	16.09	18.72	13.78	10.43	7.93	7.70	6.25	5.15	4.27
	4	59.19	37.54	32.82	23.05	16.78	12.53	9.70	7.61	6.08	4.92
	5	39.42	25.04	21.87	15.36	11.20	8.32	6.44	5.04	4.02	3.24
Z250/(3+2,5)		3.00	3.50	4.00	4.50	5.00	5.50	6.00	6.50	7.00	7.50
	1	43.72	33.63	25.75	20.35	16.45	13.57	10.89	9.70	8.34	7.25
	2	20.88	13.87	19.38	14.48	11.07	8.77	8.01	6.72	5.48	4.63
	3	23.37	15.95	18.60	13.69	10.38	7.88	7.53	6.22	5.12	4.24
	4	58.35	37.13	32.50	22.81	16.61	12.40	9.38	7.53	6.00	4.86
5	38.88	24.75	21.65	15.21	11.08	8.24	6.22	4.99	3.97	3.21	
Z250/(3+2)		3.00	3.50	4.00	4.50	5.00	5.50	6.00	6.50	7.00	7.50
	1	40.15	32.24	24.55	19.35	15.65	12.92	10.85	9.23	7.94	6.90
	2	19.04	12.30	18.22	13.63	10.43	8.12	7.98	6.55	5.35	4.48
	3	23.08	15.79	17.99	13.32	10.13	7.84	7.62	6.20	5.09	4.22
	4	57.60	36.82	32.19	22.65	16.52	12.30	9.52	7.47	5.95	4.83
5	38.36	24.54	21.45	15.10	10.90	8.17	6.31	4.94	3.93	3.18	
Z250/(3+1,5)		3.00	3.50	4.00	4.50	5.00	5.50	6.00	6.50	7.00	7.50
	1	22.15	19.15	16.72	14.83	13.10	10.87	9.18	7.85	6.79	5.90
	2	14.12	9.15	13.35	10.08	7.75	6.04	6.17	5.01	4.15	3.46
	3	22.16	15.17	13.92	10.49	8.04	6.25	6.12	4.99	4.11	3.41
	4	58.00	36.75	32.18	22.60	16.37	12.27	9.49	7.45	5.90	4.80
5	38.65	24.50	21.45	15.07	10.87	8.14	6.29	4.93	3.92	3.16	
Z250/(2+2)		3.00	3.50	4.00	4.50	5.00	5.50	6.00	6.50	7.00	7.50
	1	27.08	20.55	15.82	12.63	10.25	8.50	7.16	6.10	5.25	4.58
	2	12.07	7.95	11.03	8.31	6.45	5.00	4.89	3.90	3.22	2.68
	3	13.78	9.47	9.80	7.30	5.57	4.32	4.47	3.64	2.99	2.50
	4	39.20	24.80	21.86	15.35	11.15	8.35	6.47	5.08	4.05	3.28
5	26.10	16.54	14.55	10.23	7.40	5.55	4.30	3.37	2.68	2.17	
Z250/(2+1,5)		3.00	3.50	4.00	4.50	5.00	5.50	6.00	6.50	7.00	7.50
	1	22.14	19.10	16.24	12.95	10.50	8.65	7.28	6.18	5.33	4.62
	2	11.52	7.41	10.95	8.24	5.85	4.93	4.73	3.84	3.19	2.62
	3	13.60	9.31	9.70	7.24	5.66	4.34	4.41	3.61	2.97	2.47
	4	38.47	24.40	21.53	15.12	11.58	8.22	6.36	4.99	4.00	3.22
5	25.62	16.28	14.35	10.08	7.69	5.45	4.22	3.30	2.64	2.13	

*Unitatea de măsură exprimată în kN/m

*Tabelele sunt informative și nu înlocuiesc analiza structurală necesară pentru proiectarea clădirii - conform EN 1993-1-3.

Capacitate portantă* profile Z-SS5

Profil	Caz	Deschiderea [m]									
		3.00	3.50	4.00	4.50	5.00	5.50	6.00	6.50	7.00	7.50
Z250/(2,5+2,5)	1	36.57	27.50	21.26	17.00	13.74	11.35	9.53	8.10	6.98	6.06
	2	16.39	10.82	15.30	11.53	8.85	6.95	6.72	5.45	4.57	3.78
	3	18.42	12.58	13.25	9.85	7.47	5.85	6.00	4.89	4.00	3.33
	4	49.10	31.11	27.32	19.18	13.92	10.43	8.08	6.35	5.06	4.10
	5	32.70	20.74	15.46	12.79	9.25	6.93	5.35	4.20	3.35	2.71
Z250/(2,5+2)		3.00	3.50	4.00	4.50	5.00	5.50	6.00	6.50	7.00	7.50
	1	36.28	27.52	21.19	16.87	13.65	11.25	9.45	8.03	6.92	6.02
	2	15.94	10.40	15.35	11.55	8.77	6.91	6.60	5.34	4.46	3.68
	3	18.18	12.44	13.24	9.79	7.42	5.80	5.96	4.85	3.97	3.30
	4	48.28	30.70	27.00	18.95	13.74	10.30	7.97	6.26	5.00	4.04
5	32.15	20.47	17.97	12.63	9.13	6.84	5.29	4.14	3.30	2.67	
Z250/(2,5+1,5)		3.00	3.50	4.00	4.50	5.00	5.50	6.00	6.50	7.00	7.50
	1	22.18	19.24	16.75	14.86	12.55	10.38	8.70	7.40	6.37	5.54
	2	13.12	8.91	13.13	9.88	7.53	5.85	6.00	4.87	3.99	3.31
	3	17.95	12.60	13.10	9.73	7.40	5.78	5.80	4.68	3.83	3.16
	4	47.54	31.24	26.78	18.80	13.63	10.22	7.90	6.20	4.95	4.00
5	31.67	20.84	17.85	12.54	9.05	6.78	5.24	4.10	3.27	2.64	
Z250/(1,5+1,5)		3.00	3.50	4.00	4.50	5.00	5.50	6.00	6.50	7.00	7.50
	1	14.96	12.86	10.40	8.22	6.66	5.49	4.61	3.92	3.38	2.93
	2	8.23	5.39	7.30	5.52	4.28	3.35	3.20	2.60	2.15	1.81
	3	9.40	6.48	6.62	4.98	3.75	2.96	2.96	2.40	1.99	1.66
	4	29.24	18.49	16.34	11.99	8.32	6.24	4.84	3.80	3.03	2.45
5	19.48	12.33	10.90	6.80	5.53	4.15	3.22	2.52	2.00	1.62	
Z300/(3+3)		3.00	3.50	4.00	4.50	5.00	5.50	6.00	6.50	7.00	7.50
	1	62.80	48.50	37.10	29.30	23.75	19.60	16.45	14.00	12.05	10.50
	2	31.00	20.95	28.40	21.60	16.75	13.25	12.50	10.25	8.64	7.22
	3	33.30	23.00	24.80	18.65	14.40	11.25	11.45	9.40	7.75	6.53
	4	100.60	63.35	56.40	39.60	28.85	21.65	16.75	13.20	10.55	8.55
5	67.00	42.20	37.55	26.35	19.20	14.40	11.15	8.75	6.97	5.65	
Z300/(3+2,5)		3.00	3.50	4.00	4.50	5.00	5.50	6.00	6.50	7.00	7.50
	1	62.50	48.20	36.90	29.15	23.55	19.45	16.35	13.90	11.98	10.42
	2	30.50	20.45	28.65	21.75	16.85	13.30	12.30	10.10	8.50	7.12
	3	33.00	22.80	24.65	18.55	14.30	11.20	11.40	9.30	7.75	6.51
	4	99.70	62.70	55.80	39.15	28.55	21.40	16.60	13.05	10.40	8.45
5	66.40	41.75	37.15	26.10	19.00	14.25	11.05	8.65	6.90	5.60	

*Unitatea de măsură exprimată în kN/m

*Tabelele sunt informative și nu înlocuiesc analiza structurală necesară pentru proiectarea clădirii - conform EN 1993-1-3.

Capacitate portantă* profile Z-SS5

Profil	Caz	Deschiderea [m]									
		3.00	3.50	4.00	4.50	5.00	5.50	6.00	6.50	7.00	7.50
Z300/(3+2)	1	40.40	34.75	30.40	27.00	22.50	18.55	15.60	13.25	11.43	9.95
	2	29.65	19.60	28.40	21.35	16.50	12.95	12.10	9.95	8.33	6.95
	3	32.70	22.65	24.55	18.45	14.25	11.15	11.35	9.25	7.74	6.45
	4	98.80	62.15	55.35	38.85	28.30	21.25	16.45	12.95	10.32	8.35
	5	65.80	41.40	36.85	25.85	18.85	14.10	10.95	8.55	6.84	5.55
Z300/(2+2)		3.00	3.50	4.00	4.50	5.00	5.50	6.00	6.50	7.00	7.50
	1	27.20	23.35	20.45	17.05	13.85	11.45	9.60	8.20	7.05	6.13
	2	17.95	12.15	15.85	12.05	9.40	7.45	6.95	5.75	4.80	4.05
	3	19.45	13.55	14.25	10.75	8.30	6.55	6.45	5.35	4.40	3.71
	4	66.80	41.95	37.50	26.30	19.15	14.40	11.15	8.75	7.00	5.30
Z300/(2,5+2,5)		3.00	3.50	4.00	4.50	5.00	5.50	6.00	6.50	7.00	7.50
	1	42.95	36.90	29.00	23.10	18.80	15.58	13.15	11.20	9.70	8.40
	2	24.05	16.20	21.65	16.45	12.75	10.15	9.65	7.95	6.65	5.60
	3	26.05	18.05	19.20	14.45	11.15	8.80	8.80	7.30	6.05	5.10
	4	83.65	52.55	46.90	32.90	24.00	18.00	13.95	10.95	8.75	7.10
Z300/(2,5+2)		3.00	3.50	4.00	4.50	5.00	5.50	6.00	6.50	7.00	7.50
	1	40.65	34.90	29.60	23.45	18.95	15.65	13.15	11.20	9.65	8.38
	2	23.45	15.60	21.35	16.25	12.60	10.00	9.60	7.90	6.60	5.55
	3	25.80	17.90	19.05	14.40	11.05	8.75	8.75	7.20	6.00	5.05
	4	82.60	51.95	46.30	32.50	23.70	17.75	13.75	10.80	8.65	7.00
Z350/(4+4)		3.00	3.50	4.00	4.50	5.00	5.50	6.00	6.50	7.00	7.50
	1	112.15	87.35	66.70	52.75	42.65	35.25	29.60	25.20	21.70	18.90
	2	62.50	43.75	54.30	43.10	33.60	27.15	24.00	19.90	16.65	13.95
	3	57.95	40.50	51.85	39.10	29.35	23.05	22.95	18.90	15.85	13.30
	4	192.00	121.35	117.30	82.50	60.15	45.15	35.00	27.50	22.00	17.85
Z350/(4+3,5)		3.00	3.50	4.00	4.50	5.00	5.50	6.00	6.50	7.00	7.50
	1	111.75	87.00	66.45	52.45	42.50	35.10	29.50	25.10	21.60	18.75
	2	62.75	43.65	54.00	42.50	33.15	26.70	23.75	19.70	16.50	13.95
	3	57.65	40.25	51.60	38.95	29.45	23.00	22.85	18.80	15.75	13.25
	4	190.15	120.30	116.40	81.90	59.70	44.80	34.70	27.25	21.80	17.70
Z350/(4+3,5)		3.00	3.50	4.00	4.50	5.00	5.50	6.00	6.50	7.00	7.50
	1	126.85	80.25	77.45	54.50	39.75	29.80	23.10	18.10	14.50	11.75

*Unitatea de măsură exprimată în kN/m

*Tabelele sunt informative și nu înlocuiesc analiza structurală necesară pentru proiectarea clădirii - conform EN 1993-1-3.

Capacitate portantă* profile Z-SS5

Profil	Caz	Deschiderea [m]									
		3.00	3.50	4.00	4.50	5.00	5.50	6.00	6.50	7.00	7.50
Z350/(4+3)	1	93.75	80.10	53.85	52.15	42.15	34.85	29.20	24.85	21.40	18.60
	2	62.55	43.30	65.95	41.90	32.65	25.90	23.50	19.45	16.25	13.75
	3	57.30	40.05	51.40	38.85	29.45	23.10	22.75	18.75	15.70	13.20
	4	189.00	119.45	115.65	81.40	59.25	44.50	34.50	27.10	21.65	17.55
	5	125.90	79.65	77.00	54.15	39.45	29.60	22.90	18.00	14.35	11.65
Z350/(4+2,5)		3.00	3.50	4.00	4.50	5.00	5.50	6.00	6.50	7.00	7.50
	1	63.95	54.60	48.00	42.60	38.35	32.65	27.35	23.30	20.05	17.45
	2	62.00	49.00	48.10	39.20	30.50	24.20	23.10	19.10	15.95	13.45
	3	57.00	48.30	48.35	38.80	29.70	23.10	22.45	18.50	15.40	13.00
	4	187.95	119.00	115.10	90.00	64.95	48.35	34.30	26.95	21.55	17.50
5	125.15	79.25	76.70	60.00	43.25	32.15	22.80	17.90	14.30	11.60	
Z350/(4+2)		3.00	3.50	4.00	4.50	5.00	5.50	6.00	6.50	7.00	7.50
	1	40.50	34.55	30.40	27.00	24.25	22.05	20.20	18.65	16.65	14.50
	2	40.75	34.90	30.45	27.05	22.35	17.80	17.35	14.40	12.05	10.20
	3	40.95	35.00	30.55	27.15	23.00	18.35	17.40	14.35	12.00	10.15
	4	187.70	118.80	115.00	80.95	64.85	48.30	34.30	26.90	21.50	17.45
5	125.00	79.20	76.60	53.85	43.20	32.15	22.80	17.90	14.25	11.55	
Z350/(3+3)		3.00	3.50	4.00	4.50	5.00	5.50	6.00	6.50	7.00	7.50
	1	62.85	53.75	46.45	37.50	30.55	25.40	21.40	18.35	15.80	13.75
	2	43.35	30.20	35.10	28.25	22.10	17.55	16.50	13.70	11.50	9.70
	3	40.85	28.55	34.15	24.85	19.40	15.30	15.20	12.60	10.50	8.90
	4	143.25	90.60	87.80	61.80	45.05	33.80	26.20	20.60	16.45	13.35
5	95.45	60.35	58.50	41.15	30.00	22.50	17.45	13.70	10.95	8.85	
Z350/(3+2,5)		3.00	3.50	4.00	4.50	5.00	5.50	6.00	6.50	7.00	7.50
	1	62.95	53.90	46.15	38.15	30.85	25.50	21.40	18.20	15.70	13.65
	2	43.50	30.10	34.70	27.85	21.75	17.35	16.50	13.65	11.45	9.65
	3	40.45	28.35	34.00	24.70	19.25	15.25	15.10	12.50	10.45	8.85
	4	141.50	89.60	86.80	61.20	44.55	33.45	25.90	20.35	16.30	13.20
5	94.50	59.75	57.85	40.70	29.70	22.25	17.25	13.55	10.80	8.75	
Z350/(3+2)		3.00	3.50	4.00	4.50	5.00	5.50	6.00	6.50	7.00	7.50
	1	40.60	34.65	30.10	27.05	24.30	22.10	20.25	17.85	15.40	13.35
	2	40.95	29.70	30.15	27.10	21.30	16.95	16.25	13.45	11.30	9.50
	3	40.15	28.10	30.35	24.60	19.15	15.15	15.00	12.45	10.35	8.80
	4	140.45	88.85	84.15	60.65	44.20	33.15	25.70	20.20	16.05	13.10
5	93.65	59.15	56.05	40.35	29.40	22.10	17.10	13.40	10.65	8.70	

*Unitatea de măsură exprimată în kN/m

*Tabelele sunt informative și nu înlocuiesc analiza structurală necesară pentru proiectarea clădirii - conform EN 1993-1-3.

Capacitate portantă* profile Z-SS5

Profil	Caz	Deschiderea [m]									
		3.00	3.50	4.00	4.50	5.00	5.50	6.00	6.50	7.00	7.50
Z350/(3,5+3,5)	1	86.35	74.00	57.20	46.00	37.30	30.75	25.80	22.00	18.95	16.50
	2	53.45	37.35	45.85	35.60	27.80	22.15	20.60	17.00	14.35	12.10
	3	49.65	34.70	42.10	30.95	24.05	19.00	19.00	15.70	13.10	11.05
	4	167.65	106.00	102.65	72.25	52.65	39.50	30.65	24.05	19.25	15.60
	5	111.65	70.65	68.35	48.10	35.05	26.30	20.35	16.00	12.75	10.35
Z350/(3,5+3)		3.00	3.50	4.00	4.50	5.00	5.50	6.00	6.50	7.00	7.50
	1	86.45	74.00	56.95	45.85	37.05	30.60	25.70	21.90	18.85	16.40
	2	53.55	37.25	45.10	35.85	28.00	22.25	20.40	16.80	14.20	11.95
	3	49.35	34.45	41.95	31.00	23.95	18.90	18.90	15.65	13.05	11.00
	4	165.85	105.00	101.75	71.60	52.20	39.15	30.35	23.85	19.05	15.45
5	110.50	70.00	67.75	47.65	34.75	26.05	20.20	15.85	12.65	10.25	
Z350/(3,5+2,5)		3.00	3.50	4.00	4.50	5.00	5.50	6.00	6.50	7.00	7.50
	1	64.15	54.80	48.15	42.75	36.25	29.90	25.10	21.35	18.40	16.00
	2	53.40	36.85	46.15	35.95	27.85	22.20	20.10	16.60	14.00	11.80
	3	49.05	34.20	41.75	30.70	23.85	18.80	18.80	15.55	12.95	10.95
	4	164.65	104.20	101.00	71.10	51.80	38.85	30.10	23.65	18.65	15.35
5	109.55	69.35	67.25	47.30	34.50	25.85	20.00	15.70	12.55	10.15	
Z350/(3,5+2)		3.00	3.50	4.00	4.50	5.00	5.50	6.00	6.50	7.00	7.50
	1	40.70	34.60	30.40	27.00	24.25	22.05	20.20	18.60	16.70	14.55
	2	41.00	30.30	30.45	27.05	22.15	17.55	17.15	14.20	11.90	10.00
	3	41.05	34.10	30.60	27.20	22.45	17.80	17.00	14.00	11.65	9.80
	4	164.00	103.80	100.55	70.75	51.55	38.70	30.00	23.55	18.55	15.30
5	109.40	69.10	66.95	47.15	34.35	25.75	19.95	15.65	12.50	15.10	
Z350/(2+2)		3.00	3.50	4.00	4.50	5.00	5.50	6.00	6.50	7.00	7.50
	1	27.25	23.35	20.45	18.15	16.30	13.45	11.30	9.65	8.30	7.20
	2	23.80	16.70	19.25	15.10	11.80	9.45	8.80	7.30	6.15	5.20
	3	23.15	16.25	18.55	13.90	10.80	8.60	8.30	6.90	5.80	4.90
	4	95.15	60.00	58.30	41.00	29.90	22.45	17.40	13.65	10.90	8.85
5	63.25	40.00	38.85	27.30	19.90	14.90	11.55	9.10	7.25	5.90	
Z350/(2,5+2,5)		3.00	3.50	4.00	4.50	5.00	5.50	6.00	6.50	7.00	7.50
	1	43.10	36.85	32.30	28.65	23.50	19.50	16.40	14.05	12.10	10.50
	2	32.65	22.90	26.90	21.60	16.90	13.45	12.50	10.35	8.65	7.30
	3	32.35	22.65	26.95	19.35	15.05	11.90	11.55	9.55	8.00	6.75
	4	119.20	75.10	73.00	51.35	37.40	28.10	21.75	17.10	13.70	11.10
5	80.00	50.10	48.55	34.20	24.90	18.70	14.50	11.35	9.10	7.35	

*Unitatea de măsură exprimată în kN/m

*Tabelele sunt informative și nu înlocuiesc analiza structurală necesară pentru proiectarea clădirii - conform EN 1993-1-3.

Capacitate portantă* profile Z-SS5

Profil	Caz	Deschiderea [m]									
		3.00	3.50	4.00	4.50	5.00	5.50	6.00	6.50	7.00	7.50
Z350/(2,5+2)	1	40.50	34.85	30.60	27.15	24.00	19.90	16.75	14.35	12.35	10.75
	2	31.85	22.20	26.55	21.80	17.00	13.55	12.65	10.45	8.80	7.35
	3	32.05	22.45	26.80	19.10	14.95	11.85	11.45	9.50	7.90	6.70
	4	117.15	74.00	72.05	50.70	36.95	27.75	21.50	16.90	13.45	10.95
	5	78.15	49.25	48.00	33.75	24.60	18.45	14.30	11.20	8.55	7.25
Z400/(4+4)		3.00	3.50	4.00	4.50	5.00	5.50	6.00	6.50	7.00	7.50
	1	52.20	97.50	81.25	64.45	52.15	43.15	36.20	30.85	26.55	23.10
	2	19.80	49.60	65.60	50.00	39.00	31.00	29.20	24.10	20.25	17.10
	3	22.45	52.75	57.70	43.65	33.85	26.70	26.80	22.15	18.40	15.55
	4	38.20	185.20	162.15	113.80	83.00	62.25	48.25	37.90	30.35	24.65
5	25.40	123.40	108.00	75.85	55.25	41.45	32.10	25.20	20.15	16.35	
Z400/(4+3,5)		3.00	3.50	4.00	4.50	5.00	5.50	6.00	6.50	7.00	7.50
	1	52.00	97.60	81.20	64.15	51.90	42.95	36.00	30.65	26.40	23.00
	2	19.15	49.00	66.15	50.30	39.25	31.20	29.15	23.85	20.05	16.90
	3	22.30	52.45	57.45	43.50	33.75	26.60	26.65	22.00	18.35	15.45
	4	37.90	183.65	160.85	113.00	82.30	61.80	47.90	37.60	30.10	24.45
5	25.20	122.40	107.20	75.20	54.85	41.15	31.85	25.00	20.00	16.52	
Z400/(4+3)		3.00	3.50	4.00	4.50	5.00	5.50	6.00	6.50	7.00	7.50
	1	51.65	80.20	70.30	62.45	51.60	42.65	35.80	30.50	24.55	22.70
	2	18.45	48.00	66.40	50.50	39.35	31.20	28.85	23.60	19.80	16.70
	3	22.20	52.15	57.20	43.30	33.65	26.50	26.55	21.90	18.35	15.40
	4	37.60	182.35	159.85	112.20	81.75	61.40	47.55	37.35	30.10	24.25
5	25.00	121.50	106.45	74.75	54.50	40.85	31.65	24.85	20.00	16.10	
Z400/(4+2,5)		3.00	3.50	4.00	4.50	5.00	5.50	6.00	6.50	7.00	7.50
	1	38.45	54.75	48.00	42.65	38.40	34.90	31.95	28.50	24.55	21.35
	2	16.35	44.25	48.15	42.75	35.20	27.90	27.45	22.60	18.90	14.05
	3	22.05	181.50	48.35	43.00	33.50	26.40	26.45	21.85	18.20	14.90
	4	37.40	181.50	159.00	111.70	81.35	61.10	47.30	37.20	29.70	23.90
5	24.85	120.90	105.95	74.35	54.20	40.65	31.50	24.70	19.75	15.90	
Z400/(4+2)		3.00	3.50	4.00	4.50	5.00	5.50	6.00	6.50	7.00	7.50
	1	24.55	34.60	30.40	27.00	24.30	22.05	20.25	18.65	17.30	16.20
	2	12.40	33.55	30.45	27.05	24.35	20.65	20.10	16.65	14.00	11.80
	3	19.80	35.00	30.55	27.15	24.45	21.25	20.10	16.65	13.95	11.80
	4	37.45	181.25	158.95	111.60	81.30	61.05	47.25	37.15	29.70	24.10
5	24.95	120.75	105.85	74.25	54.15	40.60	31.45	24.70	19.70	16.00	

*Unitatea de măsură exprimată în kN/m

*Tabelele sunt informative și nu înlocuiesc analiza structurală necesară pentru proiectarea clădirii - conform EN 1993-1-3.

Capacitate portantă* profile Z-SS5

Profil	Caz	Deschiderea [m]									
		3.00	3.50	4.00	4.50	5.00	5.50	6.00	6.50	7.00	7.50
Z400/(3+3)	1	34.50	53.95	47.20	42.00	34.50	28.60	24.15	20.65	17.85	15.50
	2	13.05	44.20	42.20	32.25	25.25	20.10	18.70	15.55	13.05	10.95
	3	15.35	35.70	37.75	28.85	22.40	17.75	17.35	14.35	11.95	10.10
	4	28.45	138.25	121.25	85.15	62.10	46.60	36.10	28.35	22.70	18.45
	5	18.90	92.15	80.80	56.70	41.35	31.00	24.00	18.85	15.10	12.50
Z400/(3+2,5)		3.00	3.50	4.00	4.50	5.00	5.50	6.00	6.50	7.00	7.50
	1	35.10	53.95	47.30	42.00	35.15	29.15	24.45	20.80	17.95	15.60
	2	12.45	32.45	41.60	31.90	24.85	19.85	18.70	15.50	12.95	10.95
	3	15.20	35.40	37.50	28.65	22.25	17.65	17.20	14.25	11.90	10.05
	4	28.10	136.75	120.00	84.25	61.40	46.10	35.70	28.05	22.45	18.20
5	18.70	91.15	79.95	56.10	40.90	30.70	23.75	18.65	14.90	12.10	
Z400/(3+2)		3.00	3.50	4.00	4.50	5.00	5.50	6.00	6.50	7.00	7.50
	1	24.50	34.75	30.50	27.10	24.35	22.15	20.25	18.70	17.35	15.55
	2	11.50	31.30	30.50	27.15	24.35	19.35	18.40	15.25	12.70	10.75
	3	15.15	35.10	30.70	27.30	22.20	17.55	17.10	14.20	11.85	10.00
	4	28.00	135.60	119.00	83.55	60.90	45.70	35.40	27.80	22.25	18.05
5	18.55	11.67	79.30	55.65	40.55	30.40	23.55	18.50	14.75	12.00	
Z400/(3,5+3,5)		3.00	3.50	4.00	4.50	5.00	5.50	6.00	6.50	7.00	7.50
	1	43.30	74.00	65.00	53.25	43.40	36.00	30.40	26.05	22.50	19.55
	2	16.15	40.90	53.25	40.50	31.55	25.30	23.80	19.75	16.55	14.00
	3	18.75	44.00	47.35	35.85	28.00	22.05	22.00	18.20	15.20	12.85
	4	33.35	161.80	141.80	99.50	72.90	54.50	42.25	33.15	26.55	21.55
5	22.15	107.80	94.45	66.30	48.55	36.25	28.10	22.05	17.65	14.30	
Z400/(3,5+3)		3.00	3.50	4.00	4.50	5.00	5.50	6.00	6.50	7.00	7.50
	1	44.00	74.20	65.00	53.95	44.00	36.65	30.75	26.20	22.60	19.65
	2	15.50	40.10	52.75	40.35	31.50	25.15	23.90	19.60	16.60	14.05
	3	18.65	43.65	47.10	35.70	27.80	21.95	21.85	17.85	15.10	12.75
	4	33.00	160.25	140.55	98.65	71.90	54.00	41.85	32.25	26.25	21.35
5	22.00	106.80	93.60	65.70	47.85	35.90	27.85	21.45	17.45	14.20	
Z400/(3,5+2,5)		3.00	3.50	4.00	4.50	5.00	5.50	6.00	6.50	7.00	7.50
	1	38.65	54.90	48.20	42.80	38.50	35.00	30.65	26.10	22.45	19.55
	2	14.55	51.15	48.25	39.70	31.00	24.65	23.65	19.35	16.35	13.80
	3	18.55	43.35	46.95	35.55	27.75	21.85	21.75	17.85	15.00	12.70
	4	32.85	159e	139.50	98.00	71.35	53.60	41.50	32.25	26.05	21.15
5	21.85	105.95	92.90	65.25	47.55	35.65	27.60	21.45	17.30	14.05	

*Unitatea de măsură exprimată în kN/m

*Tabelele sunt informative și nu înlocuiesc analiza structurală necesară pentru proiectarea clădirii - conform EN 1993-1-3.

Capacitate portantă* profile Z-SS5

Profil	Caz	Deschiderea [m]									
		3.00	3.50	4.00	4.50	5.00	5.50	6.00	6.50	7.00	7.50
Z400/(3,5+2)	1	93.75	80.10	53.85	52.15	42.15	34.85	29.20	24.85	21.40	18.60
	2	62.55	43.30	65.95	41.90	32.65	25.90	23.50	19.45	16.25	13.75
	3	57.30	40.05	51.40	38.85	29.45	23.10	22.75	18.75	15.70	13.20
	4	189.00	119.45	115.65	81.40	59.25	44.50	34.50	27.10	21.65	17.55
	5	125.90	79.65	77.00	54.15	39.45	29.60	22.90	18.00	14.35	11.65
Z400/(2+2)		3.00	3.50	4.00	4.50	5.00	5.50	6.00	6.50	7.00	7.50
	1	63.95	54.60	48.00	42.60	38.35	32.65	27.35	23.30	20.05	17.45
	2	62.00	49.00	48.10	39.20	30.50	24.20	23.10	19.10	15.95	13.45
	3	57.00	48.30	48.35	38.80	29.70	23.10	22.45	18.50	15.40	13.00
	4	187.95	119.00	115.10	90.00	64.95	48.35	34.30	26.95	21.55	17.50
5	125.15	79.25	76.70	60.00	43.25	32.15	22.80	17.90	14.30	11.60	
Z400/(2,5+2,5)		3.00	3.50	4.00	4.50	5.00	5.50	6.00	6.50	7.00	7.50
	1	40.50	34.55	30.40	27.00	24.25	22.05	20.20	18.65	16.65	14.50
	2	40.75	34.90	30.45	27.05	22.35	17.80	17.35	14.40	12.05	10.20
	3	40.95	35.00	30.55	27.15	23.00	18.35	17.40	14.35	12.00	10.15
	4	187.70	118.80	115.00	80.95	64.85	48.30	34.30	26.90	21.50	17.45
5	125.00	79.20	76.60	53.85	43.20	32.15	22.80	17.90	14.25	11.55	
Z400/(2,5+2)		3.00	3.50	4.00	4.50	5.00	5.50	6.00	6.50	7.00	7.50
	1	62.85	53.75	46.45	37.50	30.55	25.40	21.40	18.35	15.80	13.75
	2	43.35	30.20	35.10	28.25	22.10	17.55	16.50	13.70	11.50	9.70
	3	40.85	28.55	34.15	24.85	19.40	15.30	15.20	12.60	10.50	8.90
	4	143.25	90.60	87.80	61.80	45.05	33.80	26.20	20.60	16.45	13.35
5	95.45	60.35	58.50	41.15	30.00	22.50	17.45	13.70	10.95	8.85	

*Unitatea de măsură exprimată în kN/m

*Tabelele sunt informative și nu înlocuiesc analiza structurală necesară pentru proiectarea clădirii - conform EN 1993-1-3.

Legendă

Sistem static fără bare de stabilizare

Sistem static cu o bară de stabilizare

Sistem static cu două bare de stabilizare





II.2 PROFIL C

2.1 Caracteristici generale

Se utilizează în special ca rigle de perete

Caracteristici tehnice

- înălțimea secțiunilor: 100-400 mm;
- $b_1, b_2 = 38 \div 100 \text{ mm}$; $c_1, c_2 = 13 \div 30 \text{ mm}$; $(c_1/b_1) \text{ max} = 0.4$; $(c_2/b_2) \text{ max} = 0.4$; $(b_1, b_2 / h) \text{ max} = 0.5$; $r = 4 \text{ mm}$
- unghiurile de îndoire $\approx 90^\circ$;
- grosimi: de la 1- la 4 mm;
- lungimi de tăiere standard: 2000- 13500 mm; pentru alte lungimi vă rugăm contactați departamentul tehnic TeraSteel;
- profilele pot fi realizate cu pregătire automată;
- profilele pot fi realizate cu laturi egale sau inegale;
- calitate material: S350GD+Z275.

2.2 Dimensiuni secționale și caracteristici geometrice

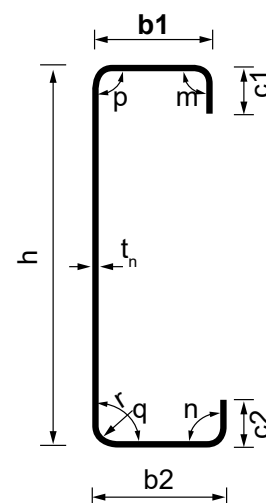

	TIP	Dimensiuni secționale							
		h (mm)	b ₁ (mm)	b ₂ (mm)	c (mm)	t _n (mm)	t (mm)	r _i (mm)	G (kg/m)
C100	C100-1.5	100	47	40	17.1	1.5	1.42	4.0	2.44
	C100-2	100	47	40	18.3	2	1.91	4.0	3.25
C120	C120-1.5	120	47	40	17.1	1.5	1.42	4.0	2.67
	C120-2	120	47	40	18.3	2.0	1.91	4.0	3.56
	C120-2.5	120	47	40	19.5	2.5	2.40	4.0	4.45
C150	C150-1.5	150	47	40	17.1	1.5	1.42	4.0	3.03
	C150-2	150	47	40	18.3	2.0	1.91	4.0	4.04
	C150-2.5	150	47	40	19.5	2.5	2.40	4.0	5.04
C180	C180-1.5	180	60	53	20.6	1.5	1.42	4.0	3.77
	C180-2	180	60	53	21.8	2.0	1.91	4.0	5.02
	C180-2.5	180	60	53	23.0	2.5	2.40	4.0	6.28
C200	C200-1.5	200	72	65	23.6	1.5	1.42	4.0	4.36
	C200-2	200	72	65	24.8	2.0	1.91	4.0	5.81
	C200-2.5	200	72	65	26.0	2.5	2.40	4.0	7.26
C250	C250-1.5	250	72	65	23.6	1.5	1.42	4.0	4.95
	C250-2	250	72	65	24.8	2.0	1.91	4.0	6.59
	C250-2.5	250	72	65	26.0	2.5	2.40	4.0	8.24
	C250-3	250	72	65	27.2	3.0	2.90	4.0	9.89
C300	C300-2	300	88	81	23.8	2.0	1.91	4.0	7.85
	C300-2.5	300	88	81	25.0	2.5	2.40	4.0	9.81
	C300-3	300	88	81	26.2	3.0	2.90	4.0	11.77
C350	C350-2	350	100	93	24.8	2.0	1.91	4.0	9.04
	C350-2.5	350	100	93	26.0	2.5	2.40	4.0	11.30
	C350-3	350	100	93	27.2	3.0	2.90	4.0	13.56
	C350-3.5	350	100	93	28.5	3.5	3.40	4.0	15.83
	C350-4	350	100	93	29.7	4.0	3.90	4.0	18.09
C400	C400-2	400	100	93	24.8	2.0	1.91	4.0	9.83
	C400-2.5	400	100	93	26.0	2.5	2.40	4.0	12.28
	C400-3	400	100	93	27.2	3.0	2.90	4.0	14.74
	C400-3.5	400	100	93	28.5	3.5	3.40	4.0	17.20
	C400-4	400	100	93	29.7	4.0	3.90	4.0	19.66

	TIP	Caracteristici geometrice ale secțiunii brute										
		A (mm ²)	y _G (mm)	z _{G1} (mm)	z _{G2} (mm)	I _y (mm ⁴)	W _{y1} (mm ³)	W _{y2} (mm ³)	I _z (mm ⁴)	I _t (mm ⁴)	i _y (mm)	i _z (mm)
C100	C100-1.5	293.5	14.4	47.6	51.0	450,736.61	9,465.16	8,845.01	82,397.14	197	39.2	16.8
	C100-2	394.7	14.5	47.4	50.7	596,284.67	12,584.16	11,759.59	109,999.85	480	38.9	16.7
C120	C120-1.5	321.9	13.1	57.5	61.1	693,190.96	12,064.08	11,341.31	87,767.17	216	46.4	16.5
	C120-2	432.9	13.2	57.2	60.9	920,079.50	16,079.26	15,115.85	117,297.15	526	46.1	16.5
	C120-2.5	543.9	13.3	57.0	60.6	1,140,352.68	20,011.84	18,812.70	146,308.43	1044	45.8	16.4
C150	C150-1.5	364.5	11.6	72.3	76.3	1,179,328.70	16,319.72	15,453.23	94,253.13	245	56.9	16.1
	C150-2	490.2	11.7	72.0	76.1	1,570,469.44	21,804.34	20,646.56	126,110.72	596	56.6	16.0
	C150-2.5	615.9	11.7	71.8	75.8	1,953,056.27	27,206.24	25,761.52	157,487.43	1183	56.3	16.0
C180	C180-1.5	466.5	15.9	87.4	91.2	2,276,862.08	26,054.80	24,967.63	213,617.01	314	69.9	21.4
	C180-2	628.3	16.0	87.2	90.9	3,045,336.97	34,943.55	33,487.39	286,832.13	764	69.6	21.4
	C180-2.5	790.6	16.1	86.9	90.7	3,804,381.69	43,772.33	41,950.65	359,574.30	1518	69.4	21.3
C200	C200-1.5	537.5	20.0	97.5	101.1	3,307,434.72	33,938.48	32,706.02	365,680.02	361	78.4	26.1
	C200-2	723.8	20.1	97.2	100.9	4,425,864.66	45,526.34	43,874.95	491,303.73	880	78.2	26.1
	C200-2.5	910.6	20.2	97.0	100.6	5,531,902.47	57,043.38	54,976.59	616,372.60	1748	77.9	26.0
C250	C250-1.5	608.5	17.7	122.3	126.3	5,588,723.17	45,711.90	44,242.47	390,849.19	409	95.8	25.3
	C250-2	819.3	17.8	122.0	126.1	7,490,569.07	61,387.66	59,416.31	525,434.71	996	95.6	25.3
	C250-2.5	1030.6	17.8	121.8	125.8	9,377,819.49	77,005.08	74,534.70	659,592.29	1979	95.4	25.3
	C250-3	1246.4	17.9	121.5	125.6	11,286,616.92	92,865.09	89,888.64	795,551.35	3494	95.2	25.3
C300	C300-2	972.1	20.8	147.0	151.1	12,877,008.87	87,601.62	85,224.65	895,328.90	1182	115.1	30.3
	C300-2.5	1222.6	20.9	146.8	150.8	16,138,255.18	109,967.15	106,985.85	1,126,223.71	2347	114.9	30.4
	C300-3	1478.4	21.0	146.5	150.6	19,444,631.59	132,718.55	129,123.23	1,361,350.78	4145	114.7	30.3
C350	C350-2	1117.3	23.0	172.0	176.1	20,052,154.64	116,607.88	113,850.07	1,305,697.54	1359	134.0	34.2
	C350-2.5	1405.0	23.1	171.7	175.9	25,144,471.97	146,425.66	142,965.23	1,643,251.75	2698	133.8	34.2
	C350-3	1698.8	23.2	171.5	175.6	30,313,993.80	176,782.55	172,607.52	1,987,529.18	4762	133.6	34.2
	C350-3.5	1994.4	23.3	171.2	175.4	35,487,018.19	207,245.27	202,357.41	2,338,502.96	7685	133.4	34.2
	C350-4	2288.5	23.4	171.0	175.1	40,591,617.33	237,397.78	231,800.66	2,679,741.22	11603	133.2	34.2
C400	C400-2	1212.8	21.2	196.9	201.2	27,544,994.01	139,928.38	136,876.79	1,352,352.66	1475	150.7	33.4
	C400-2.5	1525.0	21.3	196.6	201.0	34,556,850.25	175,763.55	171,933.08	1,702,348.10	2928	150.5	33.4
	C400-3	1843.8	21.4	196.4	200.7	41,682,484.24	212,271.50	207,648.29	2,059,468.74	5169	150.4	33.4
	C400-3.5	2163.8	21.5	196.1	200.5	48,800,424.27	248,830.90	243,416.49	2,420,310.05	8338	150.2	33.4
	C400-4	2483.5	21.6	195.9	200.2	55,872,277.07	285,247.55	279,044.59	2,778,062.85	12591	150.0	33.4

		Caracteristici geometrice ale secțiunii transversale eficace									
		TIP	Solicitarea de compresiune				Încovoiere după axa y-y cu talpa b_1 solicitată la compresiune				
			A_{ef} (mm ²)	y_{Gefc} (mm)	z_{Gefc1} (mm)	z_{Gefc2} (mm)	z_{Gefi1} (mm)	z_{Gefi2} (mm)	$I_{y,ef}$ (mm ⁴)	$W_{y,ef1}$ (mm ³)	$W_{y,ef2}$ (mm ³)
C100	C100-1.5	227.4	17.7	47.8	50.8	48.3	50.3	441,645	9,141	8,787	
	C100-2	346.1	17.3	47.4	50.7	47.4	50.7	596,285	12,584	11,760	
C120	C120-1.5	227.6	17.4	57.5	61.1	58.4	60.2	676,539	11,582	11,244	
	C120-2	350.8	16.9	57.3	60.8	57.3	60.8	917,822	16,013	15,103	
	C120-2.5	479.6	16.2	56.7	60.9	57.0	60.6	1,140,353	20,012	18,813	
C150	C150-1.5	227.1	16.9	72.2	76.4	73.8	74.8	1,142,283	15,473	15,280	
	C150-2	353.7	16.5	72.0	76.1	72.4	75.7	1,559,425	21,552	20,591	
	C150-2.5	491.5	15.9	71.3	76.3	71.8	75.8	1,953,056	27,206	25,762	
C180	C180-1.5	252.3	22.3	89.3	89.3	95.8	82.8	1,999,211	20,865	24,156	
	C180-2	412.0	22.2	87.2	90.8	88.8	89.3	2,959,838	33,338	33,143	
	C180-2.5	579.6	21.8	87.0	90.6	87.5	90.1	3,763,252	42,988	41,787	
C200	C200-1.5	258.5	26.6	98.2	100.3	112.5	86.1	2,672,425	23,761	31,035	
	C200-2	442.8	27.1	98.5	99.6	102.0	96.1	4,125,241	40,448	42,926	
	C200-2.5	634.9	26.9	97.2	100.4	98.5	99.1	5,400,164	54,801	54,515	
C250	C250-1.5	255.6	25.8	123.1	125.4	144.7	103.9	4,326,066	29,895	41,649	
	C250-2	439.2	26.3	123.4	124.7	132.2	115.9	6,714,974	50,802	57,932	
	C250-2.5	633.5	26.2	121.8	125.8	124.7	122.9	9,060,225	72,666	73,710	
	C250-3	843.7	25.8	121.6	125.5	122.6	124.5	11,127,715	90,741	89,402	
C300	C300-2	426.5	28.7	148.1	150.0	170.2	127.9	10,334,233	60,724	80,796	
	C300-2.5	647.8	29.7	148.4	149.2	158.9	138.7	14,426,763	90,806	103,995	
	C300-3	883.9	29.9	146.8	150.3	151.2	145.9	18,539,798	122,626	127,063	
C350	C350-2	420.7	30.5	173.4	174.7	208.2	139.9	14,767,182	70,927	105,565	
	C350-2.5	650.4	32.1	173.3	174.3	194.3	153.3	20,965,609	107,908	136,754	
	C350-3	914.1	33.0	173.0	174.1	183.9	163.2	27,450,486	149,278	168,189	
	C350-3.5	1183.5	33.3	171.6	175.0	176.7	169.9	33,815,806	191,395	199,011	
	C350-4	1464.6	33.1	171.3	174.8	174.1	172.0	39,405,131	226,332	229,104	
C400	C400-2	418.0	29.8	198.7	199.4	242.2	155.9	19,578,052	80,839	125,577	
	C400-2.5	643.8	31.3	198.0	199.6	226.6	171.0	27,939,157	123,280	163,417	
	C400-3	908.5	32.4	198.0	199.1	215.0	182.1	36,685,662	170,616	201,480	
	C400-3.5	1178.7	32.6	196.4	200.2	206.9	189.7	45,278,252	218,867	238,653	
	C400-4	1463.7	32.5	196.1	200.0	200.5	195.6	53,831,816	268,423	275,282	

TIP	Caracteristici geometrice ale secțiunii transversale eficace					Rezistențe după EN 1993.1.1			
	Încovoiere după axa y-y cu talpa b_2 solicitată la compresie					Întindere	Compresie	Încovoiere	
	Z_{Gef11} (mm)	Z_{Gef12} (mm)	$I_{y,ef}$ (mm ⁴)	$W_{y,ef1}$ (mm ³)	$W_{y,ef2}$ (mm ³)	$N_{t,Rd}$ (kN)	$N_{c,Rd}$ (kN)	$M_{y,Rd}$ (kNm)	
C100	C100-1.5	50.8	47.8	451,578	8,890	9,450	102.72	79.59	3.08
	C100-2	50.4	47.7	600,540	11,924	12,583	138.15	121.14	4.12
C120	C120-1.5	61.1	57.5	691,538	11,320	12,029	112.66	79.67	3.94
	C120-2	60.5	57.6	926,052	15,308	16,078	151.52	122.78	5.29
	C120-2.5	60.2	57.4	1,148,816	19,085	20,012	190.38	167.85	6.58
C150	C150-1.5	77.3	71.2	1,156,733	14,956	16,238	127.57	79.49	5.23
	C150-2	75.6	72.4	1,579,815	20,883	21,808	171.58	123.79	7.21
	C150-2.5	75.3	72.3	1,966,307	26,098	27,213	215.58	172.03	9.02
C180	C180-1.5	97.9	80.7	2,061,890	21,058	25,561	163.27	88.31	7.30
	C180-2	91.6	86.5	3,004,828	32,795	34,752	219.91	144.19	11.48
	C180-2.5	90.5	87.1	3,812,878	42,135	43,772	276.70	202.84	14.63
C200	C200-1.5	113.7	84.9	2,778,237	24,445	32,713	188.12	90.48	8.32
	C200-2	104.2	93.9	4,223,631	40,540	44,978	253.33	154.98	14.16
	C200-2.5	101.3	96.3	5,471,173	54,036	56,784	318.70	222.23	18.91
C250	C250-1.5	146.1	102.5	4,482,220	30,678	43,739	212.97	89.45	10.46
	C250-2	134.7	113.4	6,854,367	50,885	60,451	286.76	153.73	17.78
	C250-2.5	128.2	119.4	9,130,580	71,213	76,480	360.70	221.71	24.92
	C250-3	125.6	121.5	11,261,580	89,636	92,716	436.25	295.28	31.29
C300	C300-2	172.0	126.1	10,599,021	61,624	84,056	340.24	149.27	21.25
	C300-2.5	161.3	136.3	14,688,415	91,037	107,802	427.90	226.72	31.78
	C300-3	154.5	142.6	18,701,980	121,027	131,175	517.45	309.36	42.36
C350	C350-2	209.7	138.4	15,145,459	72,211	109,470	391.05	147.25	24.82
	C350-2.5	196.2	151.4	21,425,684	109,221	141,488	491.74	227.66	37.77
	C350-3	186.4	160.7	27,871,699	149,492	173,485	594.59	319.94	52.25
	C350-3.5	180.0	166.6	34,105,096	189,520	204,658	698.05	414.22	66.33
	C350-4	176.8	169.3	39,864,437	225,415	235,534	800.98	512.60	78.90
C400	C400-2	243.7	154.4	20,080,830	82,399	130,067	424.47	146.31	28.29
	C400-2.5	228.6	169.0	28,515,856	124,718	168,776	533.74	225.32	43.15
	C400-3	217.7	179.4	37,224,871	170,994	207,492	645.34	317.97	59.72
	C400-3.5	210.4	186.2	45,626,505	216,886	245,002	757.32	412.53	75.91
	C400-4	204.0	192.1	54,252,122	265,878	282,488	869.23	512.30	93.06

2.3 Metoda de montaj

Fixarea riglei de tip C

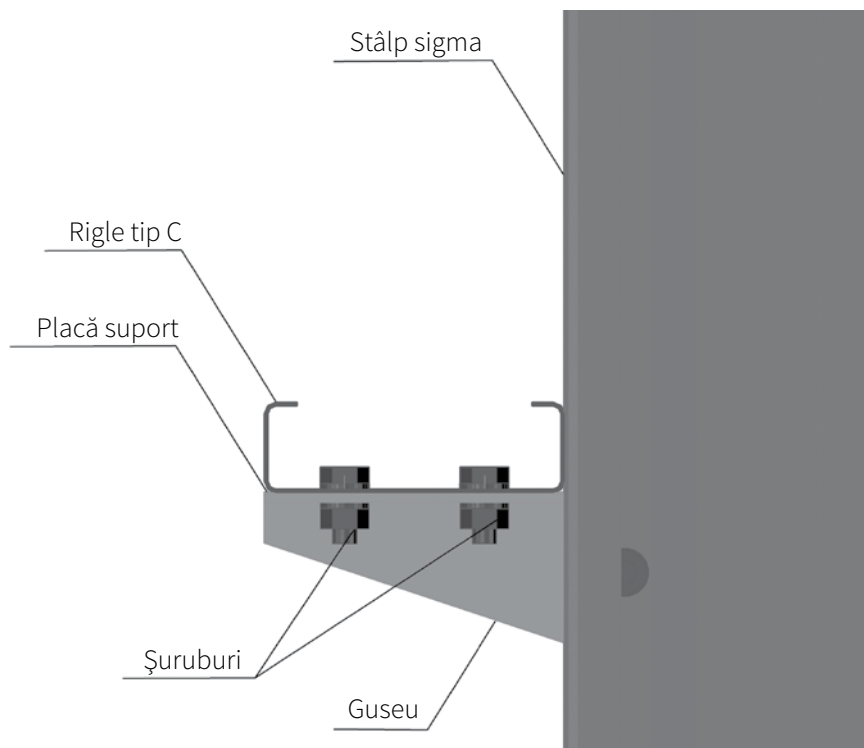

Înădirea profilelor tip C

Recomandăm următoarele:

- în deschiderile marginale $1.1L + \text{consolă}$;
- în deschiderile curente $1.0L$;
- elementele de îmbinare tip CI minim $0.2L + 150\text{mm}$.

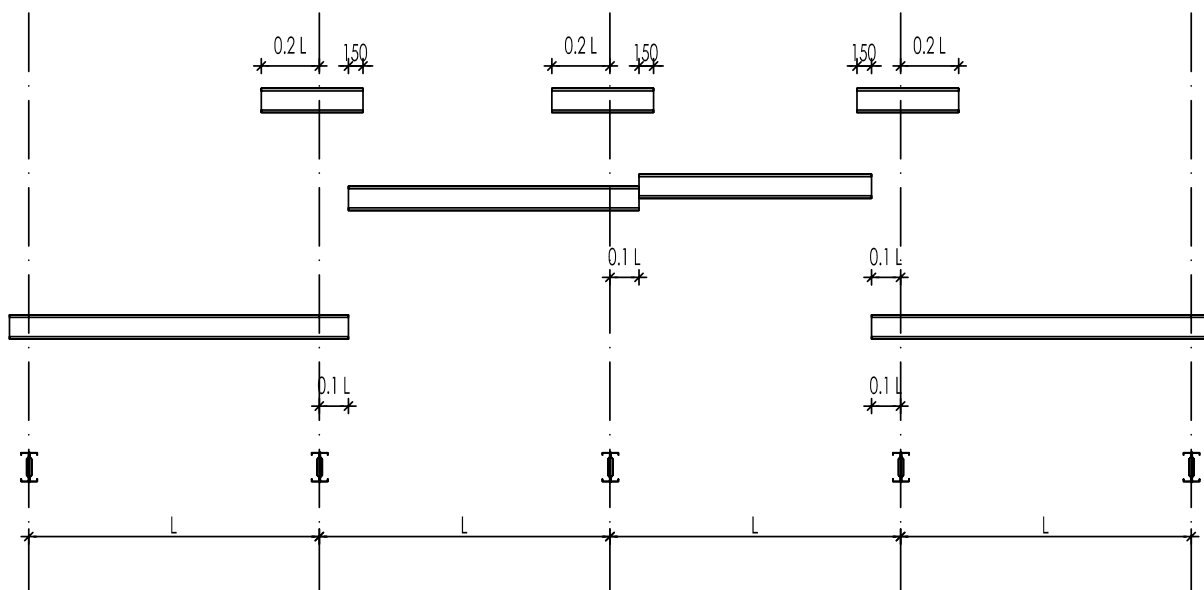

2.4 Încărcări statice

Profilele C, folosite ca rigle pentru pereți sunt analizate în varianta de grindă simplu rezemată.

În modelul de calcul simplificat pentru determinarea capacității portante a profilelor s-au considerat următoarele ipoteze:

- pentru grinzile continue pe mai multe reazeme deschiderile sunt egale;
- reazemele sunt considerate în centrul de greutate al profilelor;
- încărcarea este uniform distribuită pe toată lungimea profilului;
- lungimea suprapunerilor este de 0.2L pentru un reazem curent și de 0.3L pentru primul reazem intermediar;
- pentru diferitele sisteme statice și cazuri de încărcări talpile superioare sunt considerate fixate rezultând astfel mai multe cazuri explicate ulterior;
- cu creșterea deschiderilor tălpile inferioare sunt considerate libere, fixate în mijlocul deschiderii cu o bară de stabilizare (3.50-5.50 m) sau fixate în 2 puncte la treimi cu bare de stabilizare (6.00-6.50 m) rezultând astfel mai multe cazuri explicate mai jos.

Sistem static cu

a. o bară de stabilizare

b. doua bare stabilizatoare



Astfel s-a analizat un tip de sistem static, cu 5 cazuri de încărcare și variații ale fixărilor tălpilor care duc la o comportare mai eficientă și o îmbunătățire a capacității portante.

Sistem static nr. 1 (SS1): Grindă simplu rezemată;

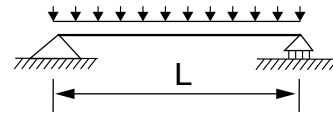

În funcție de tipul de încărcare considerat, gravitațională sau de suțiuine și de dispunerea tablei cutate, în tabel apar 3 cazuri de dimensionare în stare limită ultimă (ULS):

Caz 1: Tabla cutată se amplasează la ambele tălpi ale profilelor. Se determină capacitatea portantă din încărcarea gravitațională.

Caz 2: Tabla cutată se amplasează la talpa superioară a profilelor, iar capacitatea portantă se determină din încărcarea gravitațională.

Caz 3: Tabla cutată se amplasează la talpa superioară a profilelor, iar capacitatea portantă se determină din încărcarea din suțiuine.

Pentru dimensionarea la starea limită de serviciu (SLS) s-au considerat alte 2 cazuri care corespund unor valori limită admise pentru săgeți. Astfel s-au analizat cazurile:

Caz 4: S-a determinat încărcarea limită pentru o săgeată maximă admisă de $L/200$. Fixarea tălpilor s-a considerat doar la talpa superioară, acesta fiind cazul cel mai defavorabil.

Caz 5: S-a determinat încărcarea limită pentru o săgeată maximă admisă de $L/300$. Fixarea tălpilor s-a considerat doar la talpa superioară, acesta fiind cazul cel mai defavorabil.

Capacitate portantă* profile C-SS1

Profil	Caz	Deschiderea [m]									
		3.00	3.50	4.00	4.50	5.00	5.50	6.00	6.50	7.00	7.50
C100/1,5	1	2.96	2.16	1.65	1.30	1.06	0.86	0.73	0.61	0.52	0.45
	2	1.39	1.03	0.77	0.58	0.43	0.32	0.24	0.18	0.14	0.10
	3	0.96	0.64	0.45	0.33	0.25	0.20	0.16	0.13	0.11	0.10
	4	0.61	0.39	0.25	0.18	0.13	0.09	0.07	0.05	0.04	0.03
	5	0.40	0.25	0.16	0.11	0.08	0.05	0.04	0.02	0.02	0.01
C100/2		3.00	3.50	4.00	4.50	5.00	5.50	6.00	6.50	7.00	7.50
	1	3.91	2.88	2.20	1.73	1.40	1.15	0.97	0.82	0.70	0.61
	2	2.01	1.50	1.14	0.88	0.67	0.52	0.39	0.30	0.23	0.18
	3	1.38	0.94	0.67	0.50	0.38	0.31	0.26	0.21	0.18	0.15
	4	0.87	0.56	0.39	0.27	0.20	0.15	0.11	0.08	0.06	0.05
C120/1.5		3.00	3.50	4.00	4.50	5.00	5.50	6.00	6.50	7.00	7.50
	1	3.70	2.77	2.11	1.66	1.34	1.10	0.93	0.78	0.62	0.58
	2	2.00	1.54	1.19	0.93	0.72	0.55	0.43	0.32	0.25	0.19
	3	0.94	0.70	0.50	0.37	0.28	0.22	0.18	0.15	0.12	0.11
	4	0.90	0.62	0.42	0.29	0.21	0.16	0.12	0.09	0.07	0.056
C120/2		3.00	3.50	4.00	4.50	5.00	5.50	6.00	6.50	7.00	7.50
	1	4.98	3.70	2.82	2.22	1.80	1.47	1.24	1.05	0.90	0.78
	2	2.83	2.16	1.69	1.33	1.04	0.82	0.65	0.51	0.39	0.31
	3	1.58	1.06	0.76	0.56	0.43	0.34	0.28	0.23	0.20	0.17
	4	1.31	0.88	0.60	0.43	0.31	0.24	0.18	0.14	0.11	0.08
C120/2	5	0.90	0.57	0.39	0.27	0.20	0.14	0.11	0.08	0.06	0.04

*Unitatea de măsură exprimată în kN/m

*Tabelele sunt informative și nu înlocuiesc analiza structurală necesară pentru proiectarea clădirii - conform EN 1993-1-3.

Capacitate portantă* profile C-SS1

Profil	Caz	Deschiderea [m]									
		3.00	3.50	4.00	4.50	5.00	5.50	6.00	6.50	7.00	7.50
C120/2.5	1	6.20	4.55	3.45	2.76	2.20	1.81	1.52	1.28	1.10	0.96
	2	3.68	2.85	2.23	1.77	1.41	1.13	0.90	0.89	0.78	0.70
	3	2.43	1.63	1.15	0.86	0.65	0.52	0.42	0.35	0.30	0.26
	4	1.80	1.18	0.81	0.59	0.43	0.33	0.25	0.20	0.15	0.12
	5	0.90	0.77	0.52	0.38	0.27	0.20	0.15	0.12	0.09	0.06
C150/1.5		3.00	3.50	4.00	4.50	5.00	5.50	6.00	6.50	7.00	7.50
	1	5.05	3.67	2.79	2.21	1.78	1.46	1.23	1.04	0.89	0.77
	2	3.06	2.37	1.87	1.53	1.23	0.99	0.80	0.65	0.52	0.42
	3	1.25	0.81	0.57	0.41	0.31	0.24	0.20	0.16	0.14	0.12
	4	1.76	1.12	0.75	0.53	0.38	0.29	0.22	0.17	0.13	0.10
5	1.16	0.73	0.49	0.34	0.24	0.18	0.13	0.10	0.08	0.06	
C150/2		3.00	3.50	4.00	4.50	5.00	5.50	6.00	6.50	7.00	7.50
	1	6.80	5.00	3.80	3.03	2.43	2.00	1.67	1.42	1.22	1.06
	2	4.20	3.27	2.58	2.10	1.71	1.39	1.14	0.93	0.75	0.62
	3	1.89	1.25	0.88	0.65	0.49	0.39	0.31	0.26	0.22	0.19
	4	2.44	1.56	1.06	0.75	0.56	0.42	0.32	0.25	0.20	0.16
5	1.61	1.02	0.69	0.49	0.36	0.27	0.20	0.15	0.13	0.09	
C150/2.5		3.00	3.50	4.00	4.50	5.00	5.50	6.00	6.50	7.00	7.50
	1	8.50	6.20	4.70	3.75	3.00	2.47	2.08	1.76	1.49	1.31
	2	5.40	4.20	3.35	2.73	2.21	1.82	1.50	1.23	1.01	0.84
	3	2.55	1.71	1.22	0.90	0.70	0.55	0.45	0.38	0.32	0.28
	4	3.15	2.05	1.41	1.00	0.75	0.57	0.44	0.35	0.28	0.22
5	2.10	1.34	0.92	0.66	0.48	0.36	0.28	0.22	0.17	0.13	

*Unitatea de măsură exprimată în kN/m

*Tabelele sunt informative și nu înlocuiesc analiza structurală necesară pentru proiectarea clădirii - conform EN 1993-1-3.

Capacitate portantă* profile C-SS1

Profil	Caz	Deschiderea [m]									
		3.00	3.50	4.00	4.50	5.00	5.50	6.00	6.50	7.00	7.50
C180/1.5	1	6.93	5.02	3.9	3.05	2.45	2.04	1.7	1.45	1.24	1.08
	2	4.08	3.13	2.53	2.07	1.72	1.44	1.2	1.01	0.83	0.67
	3	2.12	1.43	1	0.73	0.55	0.43	0.34	0.28	0.23	0.2
	4	3	1.9	1.28	0.9	0.65	0.48	0.37	0.29	0.22	0.18
	5	2	1.25	0.84	0.59	0.42	0.31	0.23	0.18	0.14	0.1
C180/2		3.00	3.50	4.00	4.50	5.00	5.50	6.00	6.50	7.00	7.50
	1	10.30	7.66	5.83	4.61	3.74	3.07	2.58	2.19	1.88	1.63
	2	5.60	4.33	3.49	2.86	2.38	1.99	1.67	1.40	1.17	0.98
	3	3.13	2.11	1.49	1.09	0.82	0.64	0.51	0.42	0.35	0.30
	4	4.15	2.63	1.77	1.25	0.91	0.68	0.52	0.41	0.32	0.26
5	2.75	1.72	1.16	0.81	0.59	0.44	0.33	0.25	0.20	0.15	
C180/2.5		3.00	3.50	4.00	4.50	5.00	5.50	6.00	6.50	7.00	7.50
	1	12.92	9.55	7.28	5.75	4.65	3.84	3.22	2.74	2.35	2.04
	2	7.1	5.5	4.45	3.64	3.04	2.55	2.15	1.81	1.53	1.29
	3	4.3	2.9	2.07	1.52	1.15	0.91	0.73	0.6	0.5	0.43
	4	5.2	3.36	2.29	1.62	1.19	0.89	0.7	0.55	0.44	0.35
5	3.5	2.21	1.5	1.06	0.77	0.58	0.44	0.34	0.27	0.21	
C200/1.5		3.00	3.50	4.00	4.50	5.00	5.50	6.00	6.50	7.00	7.50
	1	8.2	5.96	4.58	3.63	2.91	2.41	2.02	1.7	1.47	1.28
	2	4.77	3.61	2.86	2.34	1.96	1.66	1.41	1.1	0.93	0.8
	3	3.01	2.06	1.47	1.09	0.83	0.64	0.51	0.42	0.35	0.29
	4	4.27	2.68	1.79	1.25	0.9	0.67	0.51	0.4	0.31	0.25
5	2.83	1.78	1.18	0.82	0.59	0.43	0.33	0.25	0.19	0.15	
C200/2		3.00	3.50	4.00	4.50	5.00	5.50	6.00	6.50	7.00	7.50
	1	13.30	9.70	7.50	5.90	4.76	3.95	3.30	2.80	2.42	2.10
	2	6.60	5.00	4.00	3.25	2.73	2.30	1.97	1.68	1.44	1.22
	3	4.35	3.00	2.14	1.58	1.20	0.94	0.75	0.61	0.50	0.43
	4	5.75	3.63	2.43	1.70	1.24	0.93	0.71	0.55	0.43	0.35
5	3.82	2.40	1.60	1.12	0.81	0.60	0.45	0.35	0.27	0.21	
C200/2.5		3.00	3.50	4.00	4.50	5.00	5.50	6.00	6.50	7.00	7.50
	1	16.87	12.50	9.50	7.50	6.10	5.04	4.22	3.60	3.07	2.68
	2	8.36	6.30	5.10	4.15	3.50	2.97	2.54	2.17	1.86	1.60
	3	5.90	4.05	2.91	2.16	1.65	1.29	1.03	0.84	0.70	0.59
	4	7.00	4.60	3.12	2.19	1.60	1.20	0.93	0.72	0.58	0.46
5	4.80	2.95	2.05	1.60	1.04	0.78	0.59	0.46	0.36	0.28	

*Unitatea de măsură exprimată în kN/m

*Tabelele sunt informative și nu înlocuiesc analiza structurală necesară pentru proiectarea clădirii - conform EN 1993-1-3.

Capacitate portantă* profile C-SS1

Profil	Caz	Deschiderea [m]									
		3.00	3.50	4.00	4.50	5.00	5.50	6.00	6.50	7.00	7.50
C250/1.5	1	10.28	7.45	5.75	4.54	3.65	3.02	2.53	2.14	1.84	1.6
	2	7.17	5.49	4.42	3.66	3.09	2.61	2.18	1.83	1.57	1.34
	3	3.73	2.53	1.79	1.31	0.99	0.76	0.6	0.49	0.4	0.34
	4	7.86	4.94	3.30	2.31	1.68	1.25	0.96	0.75	0.59	0.47
	5	5.22	3.27	2.18	1.52	1.10	0.82	0.62	0.48	0.38	0.3
C250/2		3.00	3.50	4.00	4.50	5.00	5.50	6.00	6.50	7.00	7.50
	1	16.80	12.21	9.44	7.44	5.99	4.95	4.16	3.52	3.04	2.64
	2	9.97	7.63	6.13	5.07	4.28	3.67	3.17	2.76	2.41	2.10
	3	5.36	3.64	2.58	1.89	1.42	1.10	0.87	0.71	0.58	0.49
	4	10.58	6.67	4.47	3.14	2.28	1.71	1.31	1.03	0.82	0.66
5	7.03	4.42	2.96	2.07	1.50	1.12	0.85	0.66	0.52	0.42	
C250/2.5		3.00	3.50	4.00	4.50	5.00	5.50	6.00	6.50	7.00	7.50
	1	22.90	16.99	12.93	10.25	8.32	6.84	5.74	4.89	4.20	3.65
	2	12.57	9.63	7.76	6.42	5.41	4.64	4.00	3.47	3.03	2.65
	3	7.19	4.90	3.47	2.55	1.92	1.49	1.18	0.96	0.80	0.67
	4	13.34	8.43	5.66	3.99	2.91	2.19	1.69	1.33	1.06	0.86
5	8.86	5.59	3.75	2.63	1.50	1.43	1.10	0.86	0.68	0.54	
C250/3		3.00	3.50	4.00	4.50	5.00	5.50	6.00	6.50	7.00	7.50
	1	27.57	20.45	15.07	12.32	10	8.23	6.91	5.88	5.06	4.4
	2	15.2	11.67	9.82	7.8	6.58	5.65	4.87	4.23	3.7	3.23
	3	9.3	6.34	4.5	3.31	2.51	1.95	1.56	1.27	1.05	0.89
	4	16.19	10.26	6.92	4.89	3.59	2.71	2.1	1.65	1.33	1.08
5	10.76	6.8	4.58	3.23	2.36	1.77	1.36	1.07	0.85	0.69	
C300/2		3.00	3.50	4.00	4.50	5.00	5.50	6.00	6.50	7.00	7.50
	1	21.00	15.20	11.70	9.30	7.49	6.20	5.20	4.41	3.79	3.30
	2	13.50	10.15	8.10	6.65	5.60	4.83	4.21	3.69	3.27	2.85
	3	7.70	5.35	3.83	2.84	2.16	1.68	1.33	1.08	0.94	0.74
	4	18.28	11.50	7.70	5.39	3.93	2.94	2.26	1.77	1.41	1.13
5	12.16	7.55	5.10	3.56	2.59	1.94	1.48	1.15	0.91	0.73	
C300/2.5		3.00	3.50	4.00	4.50	5.00	5.50	6.00	6.50	7.00	7.50
	1	30.79	22.4	17.3	13.64	11	9.12	7.64	6.48	5.59	4.85
	2	17.44	13.18	10.5	8.63	7.25	6.23	5.41	4.75	4.19	3.72
	3	10.26	7.12	5.1	3.78	2.87	2.24	1.78	1.44	1.19	1
	4	22.9	13.18	9.71	6.82	4.97	3.73	2.87	2.25	1.79	1.45
5	15.28	9.55	6.43	4.51	3.28	2.45	1.88	1.47	1.16	0.93	

*Unitatea de măsură exprimată în kN/m

*Tabelele sunt informative și nu înlocuiesc analiza structurală necesară pentru proiectarea clădirii - conform EN 1993-1-3.

Capacitate portantă* profile C-SS1

Profil	Caz	Deschiderea [m]									
		3.00	3.50	4.00	4.50	5.00	5.50	6.00	6.50	7.00	7.50
C300/3	1	39.53	29.38	22.32	17.69	14.38	11.84	9.94	8.48	7.28	6.33
	2	21.03	15.95	12.73	10.45	8.8	7.56	6.57	5.76	5.08	4.51
	3	13.15	9.1	6.53	4.85	3.69	2.88	2.29	1.86	1.53	1.29
	4	27.78	17.54	11.78	8.3	6.06	4.56	3.52	2.76	2.21	1.8
	5	18.49	11.66	7.81	5.49	4	3	2.3	1.8	1.44	1.16
C350/2		3.00	3.50	4.00	4.50	5.00	5.50	6.00	6.50	7.00	7.50
	1	25.3	18.43	14.22	11.21	9.03	7.48	6.27	5.32	4.58	3.98
	2	17.65	13.28	10.5	8.56	7.17	6.15	5.34	4.65	4.01	3.49
	3	10.3	7.2	5.21	3.89	2.98	2.33	1.86	1.5	1.24	1.03
	4	28.85	18.16	12.15	8.52	6.2	4.65	3.57	2.79	2.22	1.8
5	19.2	12.08	8.07	5.65	4.1	3.07	2.35	1.83	1.45	1.17	
C350/2.5		3.00	3.50	4.00	4.50	5.00	5.50	6.00	6.50	7.00	7.50
	1	37.3	27.12	20.94	16.52	13.3	11.02	9.24	7.84	6.76	5.87
	2	22.78	17.1	13.54	11.05	9.25	7.92	6.9	6.06	5.39	4.82
	3	13.62	9.51	6.88	5.14	3.94	3.08	2.45	1.99	1.64	1.37
	4	36.2	22.8	15.28	10.72	7.81	5.86	4.5	3.53	2.82	2.28
5	24.11	15.17	10.15	7.11	5.17	3.87	2.96	2.32	1.84	1.48	
C350/3		3.00	3.50	4.00	4.50	5.00	5.50	6.00	6.50	7.00	7.50
	1	50.30	36.65	28.23	22.28	17.95	14.87	12.47	10.58	9.13	7.93
	2	27.9	21	14.57	11.53	9.35	7.75	6.52	5.56	4.81	4.20
	3	17.31	12.10	8.74	6.53	5.00	3.92	3.12	2.53	2.08	1.74
	4	43.73	27.56	18.48	12.99	9.47	7.12	5.48	4.30	3.44	2.79
5	29.11	18.32	12.28	8.62	6.27	4.70	3.61	2.82	2.25	1.81	
C350/3.5		3.00	3.50	4.00	4.50	5.00	5.50	6.00	6.50	7.00	7.50
	1	61.72	45.9	34.9	27.66	22.5	18.52	15.55	13.28	11.4	9.92
	2	32.63	24.58	19.5	15.93	13.36	11.45	9.95	8.74	7.76	6.93
	3	21.32	14.91	10.78	8.06	6.18	4.84	3.88	3.13	2.58	2.16
	4	51.24	32.34	21.72	15.28	11.16	8.4	6.48	5.1	4.08	3.32
5	34.12	21.5	14.43	10.14	7.39	5.55	4.27	3.35	2.67	2.16	
C350/4		3.00	3.50	4.00	4.50	5.00	5.50	6.00	6.50	7.00	7.50
	1	70.63	52.55	39.96	31.67	25.75	21.2	17.8	15.19	13.05	11.35
	2	37.41	28.17	22.37	18.31	15.34	13.17	11.45	10.07	8.95	7.98
	3	25.62	17.93	12.98	9.72	7.45	5.85	4.68	3.8	3.14	2.63
	4	58.81	37.16	25	17.6	12.88	9.71	7.51	5.92	4.75	3.87
5	39.15	24.7	16.6	11.68	8.53	6.42	4.94	3.89	3.11	2.52	

*Unitatea de măsură exprimată în kN/m

*Tabelele sunt informative și nu înlocuiesc analiza structurală necesară pentru proiectarea clădirii - conform EN 1993-1-3.

Capacitate portantă* profile C-SS1

Profil	Caz	Deschiderea [m]									
		3.00	3.50	4.00	4.50	5.00	5.50	6.00	6.50	7.00	7.50
C400/2	1	28.65	21.05	16.25	12.78	10.31	8.52	7.15	6	5.23	4.5
	2	22.4	16.84	13.35	10.94	9.04	7.53	6.3	5.38	4.68	4.08
	3	11.9	8.3	5.97	4.45	3.4	2.64	2.1	1.7	1.52	1.16
	4	41.78	16.84	13.35	10.94	8.99	6.73	5.18	4.06	3.24	2.62
	5	27.83	16.84	11.7	8.2	5.96	4.46	3.42	2.67	2.19	1.71
C400/2.5		3.00	3.50	4.00	4.50	5.00	5.50	6.00	6.50	7.00	7.50
	1	42.58	30.9	23.8	18.85	15.17	8.53	10.55	8.93	7.73	6.7
	2	28.9	21.78	17.28	14.15	11.83	10.15	8.88	7.81	4.67	6.05
	3	15.72	10.9	7.88	5.88	4.48	3.48	2.77	2.24	1.84	1.53
	4	52.44	21.78	17.28	14.15	11.3	8.49	6.53	5.12	4.09	3.31
5	34.92	21.78	14.68	10.31	7.5	4.45	4.31	3.38	2.69	2.17	
C400/3		3.00	3.50	4.00	4.50	5.00	5.50	6.00	6.50	7.00	7.50
	1	57.16	41.64	32.08	25.32	20.41	16.83	14.1	12.7	10.38	9
	2	35.57	26.8	21.26	17.4	14.58	12.5	10.88	9.55	8.51	7.61
	3	19.94	13.9	10	7.44	5.68	4.42	3.51	2.83	2.33	1.94
	4	63.3	39.88	26.74	18.79	13.7	10.3	7.93	6.23	4.98	4.04
5	42.14	26.51	17.77	12.48	9.09	6.81	5.23	4.11	3.27	2.65	
C400/3.5		3.00	3.50	4.00	4.50	5.00	5.50	6.00	6.50	7.00	7.50
	1	71.3	51.94	40	31.6	25.45	21.08	17.7	15.02	12.95	11.26
	2	41.6	31.38	24.9	20.38	17.09	14.66	12.75	11.2	9.95	8.88
	3	24.5	17.08	12.3	9.16	7	5.45	4.34	3.5	2.88	2.4
	4	74.16	46.78	31.4	22.08	16.12	12.12	9.35	7.36	5.89	4.79
5	49.38	31.1	20.86	14.66	10.69	8.02	6.18	4.85	3.87	3.14	
C400/4		3.00	3.50	4.00	4.50	5.00	5.50	6.00	6.50	7.00	7.50
	1	85.1	63.32	48.14	38.16	31.04	25.55	21.46	18.32	15.73	13.69
	2	47.62	35.94	28.55	23.4	19.61	16.83	14.65	12.87	11.43	10.2
	3	29.43	20.49	14.76	11	8.41	6.56	5.22	4.23	3.48	2.9
	4	85	53.68	36.06	25.4	18.58	13.99	10.8	8.52	6.83	5.56
5	56.58	35.68	23.97	16.87	12.31	9.26	7.14	5.61	4.49	3.64	

*Unitatea de măsură exprimată în kN/m

*Tabelele sunt informative și nu înlocuiesc analiza structurală necesară pentru proiectarea clădirii - conform EN 1993-1-3.



II.3 PROFIL Σ

3.1 Caracteristici generale

Se utilizează în special pentru formarea stâlpilor și grinzilor compuse

Caracteristici tehnice

- înălțimea secțiunilor: 200-400 mm;
- $b_1, b_2 = 38 \div 100 \text{ mm}$; $c_1, c_2 = 13 \div 30 \text{ mm}$; $(c_1/b_1) \text{ max} = 0.4$; $(c_2/b_2) \text{ max} = 0.4$; $(b_1, b_2/h) \text{ max} = 0.5$; $32 < (d_1, d_2) < 48 \text{ mm}$; $u, v = 140^\circ$; $r = 4 \text{ mm}$;
- unghiurile de îndoire $= 90^\circ$;
- grosimi: de la 1- la 4 mm;
- lungimi de tăiere standard: 2000- 13500 mm; pentru alte lungimi vă rugăm contactați departamentul tehnic TeraSteel;
- profilele pot fi realizate cu pregăurire automată;
- profilele pot fi realizate cu laturi egale sau inegale;
- calitate material: S350GD+Z275.

3.2 Dimensiuni secționale și caracteristici geometrice

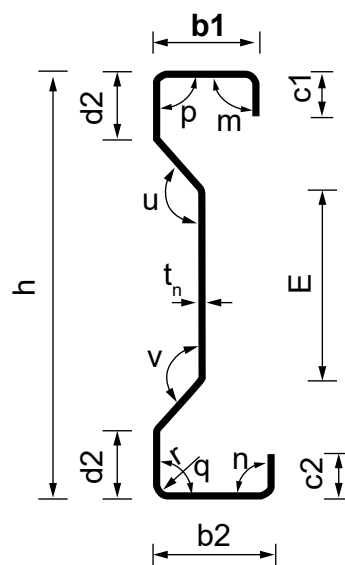

	TIP	Dimensiuni secționale									
		h (mm)	b ₁ (mm)	b ₂ (mm)	c (mm)	E (mm)	d (mm)	t _n (mm)	t (mm)	r _i (mm)	G (kg/m)
Σ200	Σ200-1.5	200	52	45	22.1	89.2	32	1.50	1.42	4.0	4.02
	Σ200-2	200	52	45	23.3	89.5	32	2.00	1.91	4.0	5.35
	Σ200-2.5	200	52	45	24.5	89.8	32	2.50	2.40	4.0	6.69
	Σ200-3	200	52	45	25.8	90.2	32	3.00	2.90	4.0	8.03
	Σ200-3.5	200	52	45	27	90.5	32	3.50	3.40	4.0	9.37
	Σ200-4	200	52	45	28.2	90.9	32	4.00	3.90	4.0	10.71
Σ250	Σ250-1.5	250	72	65	22.6	115.2	44	1.50	1.42	4.0	5.09
	Σ250-2	250	72	65	23.8	115.5	44	2.00	1.91	4.0	6.78
	Σ250-2.5	250	72	65	25	115.8	44	2.50	2.40	4.0	8.48
	Σ250-3	250	72	65	26.2	116.2	44	3.00	2.90	4.0	10.17
	Σ250-3.5	250	72	65	27.5	116.5	44	3.50	3.40	4.0	11.87
	Σ250-4	250	72	65	28.5	116.9	44	4.00	3.90	4.0	13.60
Σ300	Σ300-1.5	300	88	81	24	165.2	44	1.50	1.42	4.0	6.08
	Σ300-2	300	88	81	25.3	165.5	44	2.00	1.91	4.0	8.12
	Σ300-2.5	300	88	81	26.5	165.8	44	2.50	2.40	4.0	10.14
	Σ300-3	300	88	81	27.7	166.2	44	3.00	2.90	4.0	12.17
	Σ300-3.5	300	88	81	29	166.5	44	3.50	3.40	4.0	14.20
	Σ300-4	300	88	81	30.1	166.9	44	4.00	3.90	4.0	16.23
Σ350	Σ350-1.5	350	100	93	23.6	215.2	44	1.50	1.42	4.0	6.95
	Σ350-2	350	100	93	24.8	215.5	44	2.00	1.91	4.0	9.26
	Σ350-2.5	350	100	93	26	215.8	44	2.50	2.40	4.0	11.58
	Σ350-3	350	100	93	27.2	216.2	44	3.00	2.90	4.0	13.89
	Σ350-3.5	350	100	93	28.5	216.5	44	3.50	3.40	4.0	16.21
	Σ350-4	350	100	93	29.6	216.9	44	4.00	3.90	4.0	18.52
Σ400	Σ400-2	400	100	93	25	265.5	44	2.00	1.91	4.0	10.06
	Σ400-2.5	400	100	93	26	265.8	44	2.50	2.40	4.0	12.56
	Σ400-3	400	100	93	27.2	266.2	44	3.00	2.90	4.0	15.07
	Σ400-3.5	400	100	93	28.5	266.5	44	3.50	3.40	4.0	17.58
	Σ400-4	400	100	93	29.7	266.9	44	4.00	3.90	4.0	20.09

	TIP	Caracteristici geometrice ale secțiunii brute										
		A (mm ²)	Y _G (mm)	Z _{G1} (mm)	Z _{G2} (mm)	I _y (mm ⁴)	W _{y1} (mm ³)	W _{y2} (mm ³)	I _z (mm ⁴)	i _t (mm)	i _y (mm)	i _z (mm)
Σ200	Σ200-1.5	511.6	19.6	98.0	102.0	2,814,865	28,723	27,597	117,610	384	74.2	15.2
	Σ200-2	682.0	19.9	98.0	102.0	3,725,754	38,018	36,527	155,118	909	73.9	15.1
	Σ200-2.5	852.3	20.2	98.0	102.0	4,622,414	47,167	45,318	191,706	1,776	73.6	15.0
	Σ200-3	1023.2	20.5	98.0	102.0	5,507,857	56,203	53,999	227,766	3,070	73.4	14.9
	Σ200-3.5	1193.5	20.8	98.0	102.0	6,375,602	65,057	62,506	262,459	4,873	73.0	14.8
	Σ200-4	1363.8	21.0	98.0	102.0	7,228,221	73,757	70,865	296,128	7,273	72.8	14.7
Σ250	Σ250-1.5	648.0	24.1	123.0	127.0	5,774,032	46,943	45,465	299,380	486	94.4	21.6
	Σ250-2	864.0	24.4	123.0	127.0	7,658,133	62,261	60,300	397,353	1,152	94.2	21.5
	Σ250-2.5	1080.0	24.7	123.0	127.0	9,521,217	77,408	74,970	494,259	2,250	93.9	21.4
	Σ250-3	1296.0	25.0	123.0	127.0	11,362,865	92,381	89,471	590,010	3,888	93.7	21.3
	Σ250-3.5	1512.0	25.3	123.0	127.0	13,189,333	107,230	103,853	685,731	6,174	93.4	21.3
	Σ250-4	1732.8	25.6	123.0	127.0	15,072,511	122,541	118,681	783,591	9,242	93.3	21.3
Σ300	Σ300-1.5	775.0	28.5	148.0	152.0	10,105,168	68,278	66,481	528,060	581	114.2	26.1
	Σ300-2	1033.9	28.8	148.0	152.0	13,423,737	90,701	88,314	703,392	1,379	113.9	26.1
	Σ300-2.5	1292.3	29.1	148.0	152.0	16,708,544	112,896	109,925	876,631	2,692	113.7	26.0
	Σ300-3	1550.6	29.5	148.0	152.0	19,963,819	134,891	131,341	1,048,574	4,652	113.5	26.0
	Σ300-3.5	1809.0	29.8	148.0	152.0	23,199,299	156,752	152,627	1,221,072	7,387	113.2	26.0
	Σ300-4	2066.9	30.1	148.0	152.0	26,383,696	178,268	173,577	1,388,102	11,023	113.0	25.9
Σ350	Σ350-1.5	885.0	31.1	173.0	177.0	15,686,467	90,673	88,624	750,540	664	133.1	29.1
	Σ350-2	1180.0	31.4	173.0	177.0	20,845,352	120,493	117,770	999,409	1,573	132.9	29.1
	Σ350-2.5	1474.8	31.7	173.0	177.0	25,968,131	150,105	146,713	1,247,352	3,073	132.7	29.0
	Σ350-3	1770.0	32.1	173.0	177.0	31,054,138	179,504	175,447	1,494,216	5,310	132.5	29.0
	Σ350-3.5	2065.0	32.4	173.0	177.0	36,117,758	208,773	204,055	1,742,580	8,432	132.3	29.0
	Σ350-4	2359.0	32.7	173.0	177.0	41,113,237	237,649	232,278	1,984,114	12,581	132.0	29.0
Σ400	Σ400-2	1281.0	30.7	197.8	202.2	28,731,793	145,257	142,096	1,012,845	1,708	149.8	28.1
	Σ400-2.5	1600.0	30.9	197.8	202.2	35,781,609	180,898	176,961	1,260,146	3,333	149.6	28.1
	Σ400-3	1919.6	31.2	197.8	202.2	42,813,355	216,448	211,738	1,509,833	5,759	149.3	28.1
	Σ400-3.5	2240.0	31.6	197.8	202.2	49,822,313	251,882	246,401	1,761,183	9,147	149.1	28.0
	Σ400-4	2559.8	31.9	197.8	202.2	56,769,116	287,003	280,757	2,008,794	13,652	148.9	28.0

TIP	Caracteristici geometrice ale secțiunii transversale eficiente									
	Solicitarea de compresiune				Încovoiere după axa y-y cu talpa b_1 solicitată la compresiune					
	A_{ef} (mm ²)	$y_{Gef,c}$ (mm)	$z_{Gef,c1}$ (mm)	$z_{Gef,c2}$ (mm)	$z_{Gef,i1}$ (mm)	$z_{Gef,i2}$ (mm)	$I_{y,ef}$ (mm ⁴)	$W_{y,ef1}$ (mm ³)	$W_{y,ef2}$ (mm ³)	
Σ200	Σ200-1.5	452.1	16.2	102.0	98.0	100.4	99.6	2,541,660	25307	25527
	Σ200-2	640.7	17.2	101.4	98.6	98.9	101.1	3,464,190	35023	34269
	Σ200-2.5	829.4	17.9	100.7	99.3	98.0	102.0	4,357,660	44450	42737
	Σ200-3	1013.3	18.2	100.6	99.4	98.0	102.0	5,191,280	52962	50904
	Σ200-3.5	1186.0	18.4	100.4	99.6	98.0	102.0	5,992,580	61135	58764
	Σ200-4	1358.1	18.7	100.3	99.6	98.0	102.0	6,765,520	69018	66346
Σ250	Σ250-1.5	511.1	17.7	127.6	122.4	132.4	117.6	4,803,420	36286	40837
	Σ250-2	767.0	19.8	126.9	123.1	127.1	122.9	6,853,260	53925	55757
	Σ250-2.5	1008.2	21.1	126.4	123.6	125.4	124.6	8,722,780	69538	70028
	Σ250-3	1260.0	22.0	126.2	123.8	124.3	125.7	10,580,000	85562	84674
	Σ250-3.5	1515.6	22.7	125.8	124.2	123.5	126.5	12,420,000	100607	98197
	Σ250-4	1750.4	23.1	125.3	124.7	123.0	127.0	14,160,000	115099	111536
Σ300	Σ300-1.5	541.6	18.4	152.7	147.3	166.2	133.8	7,827,610	47084	58523
	Σ300-2	825.6	21.3	152.4	147.6	158.8	141.2	11,250,000	70872	79699
	Σ300-2.5	1118.6	23.2	151.4	148.6	153.5	146.5	14,880,000	96962	101537
	Σ300-3	1403.4	24.5	151.2	148.8	151.5	148.5	18,190,000	120070	122428
	Σ300-3.5	1696.8	25.6	151.0	149.0	150.3	149.7	21,370,000	142139	142778
	Σ300-4	1994.1	26.4	150.8	149.2	149.4	150.6	24,540,000	164292	162972
Σ350	Σ350-1.5	561.5	18.4	177.3	172.7	200.2	149.8	11,550,000	57711	77107
	Σ350-2	850.3	21.3	177.4	172.6	191.5	158.5	16,720,000	87282	105491
	Σ350-2.5	1171.2	23.8	177.0	173.0	184.6	165.4	22,190,000	120202	134149
	Σ350-3	1480.3	25.5	176.2	173.8	180.4	169.6	27,530,000	152573	162315
	Σ350-3.5	1794.1	26.9	176.0	174.0	177.5	172.5	32,760,000	184533	189943
	Σ350-4	2113.2	27.9	175.8	174.2	176.1	173.9	37,900,000	215258	217887
Σ400	Σ400-2	828.8	21.1	202.3	197.7	222.2	177.8	22,630,000	101853	127241
	Σ400-2.5	1139.1	23.6	201.6	198.4	214.1	185.9	30,100,000	140544	161922
	Σ400-3	1446.8	25.3	201.1	198.9	209.3	190.7	37,380,000	178614	196029
	Σ400-3.5	1752.7	26.7	200.8	199.2	205.7	194.3	44,630,000	217023	229685
	Σ400-4	2065.1	27.8	200.5	199.5	202.8	197.2	51,820,000	255493	262793

TIP	Caracteristici geometrice ale secțiunii transversale eficace					
	Încovoiere după axa y-y cu talpa b_2 sollicitată la compresie					
	$z_{Gef.1}$ (mm)	$z_{Gef.2}$ (mm)	$I_{y,ef}$ (mm ⁴)	$W_{y,ef.1}$ (mm ³)	$W_{y,ef.2}$ (mm ³)	
Σ200	Σ200-1.5	95.8	104.2	2,537,480	26485	24354
	Σ200-2	97.5	102.5	3,468,920	35581	33841
	Σ200-2.5	97.8	102.2	4,314,740	44119	42218
	Σ200-3	97.8	102.2	5,126,240	52438	50139
	Σ200-3.5	97.7	102.3	5,903,200	60411	57715
	Σ200-4	97.7	102.3	6,647,960	68061	64970
Σ250	Σ250-1.5	112.2	137.8	4,656,370	41517	33780
	Σ250-2	118.1	131.9	6,728,120	56956	51020
	Σ250-2.5	120.3	129.7	8,629,590	71756	66516
	Σ250-3	121.8	128.2	10,540,000	86532	82227
	Σ250-3.5	122.8	127.2	12,390,000	100903	97401
	Σ250-4	122.8	127.2	14,010,000	114166	110142
Σ300	Σ300-1.5	125.8	174.2	7,347,020	58410	42172
	Σ300-2	135.0	165.0	10,920,000	80873	66154
	Σ300-2.5	140.8	159.2	14,470,000	102806	90871
	Σ300-3	143.6	156.4	17,880,000	124506	114317
	Σ300-3.5	145.4	154.6	21,230,000	146026	137311
	Σ300-4	146.7	153.3	24,510,000	166994	159894
Σ350	Σ350-1.5	138.4	211.6	10,450,000	75494	49353
	Σ350-2	149.0	201.0	15,600,000	104700	77652
	Σ350-2.5	157.6	192.4	21,180,000	134399	110088
	Σ350-3	162.9	187.1	26,620,000	163456	142285
	Σ350-3.5	166.8	183.2	32,050,000	192157	174969
	Σ350-4	168.8	181.2	37,240,000	220547	205538
Σ400	Σ400-2	167.0	233.0	21,000,000	125739	90113
	Σ400-2.5	176.7	223.3	28,540,000	161510	127811
	Σ400-3	183.1	216.9	36,050,000	196885	166225
	Σ400-3.5	187.9	212.1	43,570,000	231834	205482
	Σ400-4	191.7	208.3	51,010,000	266153	244863

3.3 Metoda de montaj

Detaliu de stâlp sau grindă

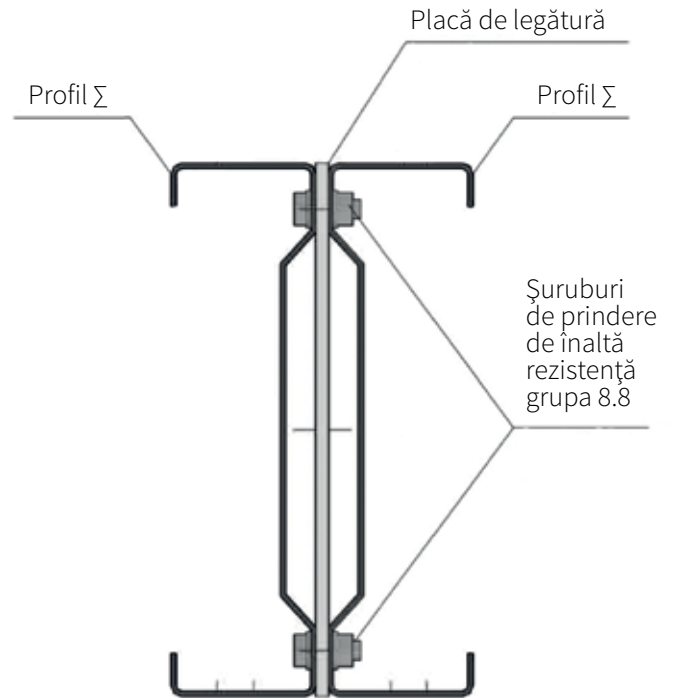

	TIP	Rezistențe după EN 1993.1.1		
		Întindere	Compresie	Încovoiere
		$N_{t,Rd}$ (kN)	$N_{c,Rd}$ (kN)	$M_{y,Rd}$ (kNm)
Σ200	Σ200-1.5	179.04	158.24	8.52
	Σ200-2	238.68	224.25	11.84
	Σ200-2.5	298.30	290.29	14.78
	Σ200-3	358.11	354.66	17.55
	Σ200-3.5	417.73	415.10	20.20
	Σ200-4	477.32	475.34	22.74
Σ250	Σ250-1.5	226.80	178.89	11.82
	Σ250-2	302.40	268.45	17.86
	Σ250-2.5	378.00	352.87	23.28
	Σ250-3	453.60	441.00	28.78
	Σ250-3.5	529.20	530.46	34.09
	Σ250-4	606.49	612.64	38.55
Σ300	Σ300-1.5	271.25	189.56	14.76
	Σ300-2	361.87	288.96	23.15
	Σ300-2.5	452.30	391.51	31.80
	Σ300-3	542.70	491.19	40.01
	Σ300-3.5	633.15	593.88	48.06
	Σ300-4	723.42	697.94	55.96
Σ350	Σ350-1.5	309.75	196.53	17.27
	Σ350-2	413.00	297.61	27.18
	Σ350-2.5	516.18	409.92	38.53
	Σ350-3	619.50	518.11	49.80
	Σ350-3.5	722.75	627.94	61.24
	Σ350-4	825.65	739.62	71.94
Σ400	Σ400-2	448.35	290.08	31.54
	Σ400-2.5	560.00	398.69	44.73
	Σ400-3	671.85	506.38	58.18
	Σ400-3.5	784.00	613.45	71.92
	Σ400-4	895.92	722.79	85.70



II.4 PROFIL U

4.1 Caracteristici generale

Se utilizează în special ca și profil de ghidaj

Caracteristici tehnice

- înălțimea secțiunilor: 100-400 mm;
- $b_1, b_2 = 38-100\text{mm}$; $(b_1, b_2 / h) \text{ max}=0.6$; $r=4 \text{ mm}$
- unghiurile de îndoire $=90^\circ$;
- grosimi: de la 1- la 4 mm;
- lungimi de tăiere standard: 2000- 13500 mm;
pentru alte lungimi vă rugăm contactați departamentul tehnic TeraSteel;
- profilele pot fi realizate cu pregătire automată;
- profilele pot fi realizate cu laturi egale sau inegale;
- calitate material: S350GD+Z275.

4.2 Dimensiuni secționale și caracteristici geometrice

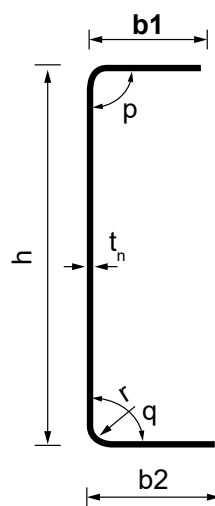

	TIP	Dimensiuni secționale						
		h (mm)	b ₁ (mm)	b ₂ (mm)	t _n (mm)	t (mm)	r _i (mm)	G (kg/m)
U100	U100-1.5	103	55	55	1.5	1.42	4.0	2.42
	U100-2	104	55	55	2.0	1.91	4.0	3.23
U120	U120-1.5	123	55	55	1.5	1.42	4.0	2.66
	U120-2	124	55	55	2.0	1.91	4.0	3.54
	U120-2.5	125	55	55	2.5	2.40	4.0	4.44
U150	U150-1.5	153	55	55	1.5	1.42	4.0	3.01
	U150-2	154	55	55	2.0	1.91	4.0	4.01
	U150-2.5	155	55	55	2.5	2.40	4.0	5.03
U180	U180-1.5	183	55	55	1.5	1.42	4.0	3.37
	U180-2	184	55	55	2.0	1.91	4.0	4.48
	U180-2.5	185	55	55	2.5	2.40	4.0	5.62
U200	U200-1.5	203	75	75	1.5	1.42	4.0	4.07
	U200-2	204	75	75	2.0	1.91	4.0	5.43
	U200-2.5	205	75	75	2.5	2.40	4.0	6.80
U250	U250-1.5	253	75	75	1.5	1.42	4.0	4.66
	U250-2	254	75	75	2.0	1.91	4.0	6.21
	U250-2.5	255	75	75	2.5	2.40	4.0	7.78
	U250-3	256	75	75	3.0	2.90	4.0	9.33
U300	U300-2	304	75	75	2.0	1.91	4.0	6.99
	U300-2.5	305	75	75	2.5	2.40	4.0	8.76
	U300-3	306	75	75	3.0	2.90	4.0	10.51
U350	U350-2	354	100	100	2.0	1.91	4.0	8.56
	U350-2.5	355	100	100	2.5	2.40	4.0	10.71
	U350-3	356	100	100	3.0	2.90	4.0	12.86
	U350-3.5	357	100	100	3.5	3.40	4.0	15.00
	U350-4	358	100	100	4.0	3.90	4.0	17.14
U400	U400-2	404	100	100	2.0	1.91	4.0	9.35
	U400-2.5	405	100	100	2.5	2.40	4.0	11.69
	U400-3	406	100	100	3.0	2.90	4.0	14.04
	U400-3.5	407	100	100	3.5	3.40	4.0	16.38
	U400-4	408	100	100	4.0	3.90	4.0	18.71

	TIP	Caracteristici geometrice ale secțiunii brute										
		A (mm ²)	Y _G (mm)	Z _{G1} (mm)	Z _{G2} (mm)	I _y (mm ⁴)	W _{y1} (mm ³)	W _{y2} (mm ³)	I _z (mm ⁴)	I _t (mm ⁴)	i _y (mm)	i _z (mm)
U100	U100-1.5	308.8	15.0	51.5	51.5	533,737	10,364	10,364	96,481	231.6	41.5	17.6
	U100-2	411.4	15.2	52.0	52.0	715,850	13,766	13,766	127,193	548.5	41.7	17.5
U120	U120-1.5	338.8	13.8	61.5	61.5	801,791	13,037	13,037	102,082	254.1	48.6	17.3
	U120-2	451.0	13.9	62.0	62.0	1,073,814	17,320	17,320	134,546	601.3	48.7	17.2
	U120-2.5	566.0	14.3	62.5	65.5	1,357,589	21,721	20,727	170,478	1179.2	48.9	17.4
U150	U150-1.5	383.8	12.3	76.5	76.5	1,332,828	17,423	17,423	108,845	287.9	58.9	16.8
	U150-2	511.4	12.4	77.0	77.0	1,782,541	23,150	23,150	143,423	681.9	59.0	16.7
	U150-2.5	641.0	12.7	77.5	77.5	2,249,488	29,026	29,026	181,721	1335.4	59.2	16.8
U180	U180-1.5	428.8	11.1	91.5	91.5	2,036,614	22,258	22,258	114,190	321.6	68.9	16.3
	U180-2	571.0	11.2	92.0	92.0	2,721,406	29,580	29,580	150,440	761.3	69.0	16.2
	U180-2.5	716.2	11.5	92.5	92.5	3,429,943	37,080	37,080	190,617	1492.1	69.2	16.3
U200	U200-1.5	518.8	16.7	101.5	101.5	3,220,820	31,732	31,732	277,478	389.1	78.8	23.1
	U200-2	691.4	16.8	102.0	102.0	4,304,610	42,202	42,202	366,779	921.9	78.9	23.0
	U200-2.5	866.2	17.2	102.5	102.5	5,419,096	52,869	52,869	462,989	1804.6	79.1	23.1
U250	U250-1.5	593.8	14.6	126.5	126.5	5,413,121	42,791	42,791	294,157	445.4	95.5	22.3
	U250-2	791.0	14.8	127.0	127.0	7,228,841	56,920	56,920	388,756	1054.7	95.6	22.2
	U250-2.5	991.0	15.2	127.5	127.5	9,090,037	71,294	71,294	490,737	2064.6	95.8	22.3
	U250-3	1188.8	15.3	128.0	128.0	10,925,144	85,353	85,353	583,782	3566.4	95.9	22.2
U300	U300-2	891.0	13.3	152.0	152.0	11,142,342	73,305	73,305	405,809	1188.0	111.8	21.3
	U300-2.5	1116.2	13.6	152.5	152.5	14,000,020	91,803	91,803	512,286	2325.5	111.9	21.4
	U300-3	1338.8	13.7	153.0	153.0	16,818,051	109,922	109,922	609,354	4016.4	112.0	21.3
U350	U350-2	1091.0	19.0	177.5	177.5	19,267,747	108,551	108,551	941,712	1454.7	132.9	29.4
	U350-2.5	1363.7	19.1	177.5	177.5	24,110,707	135,835	135,835	1,169,344	2841.1	133.0	29.3
	U350-3	1638.8	19.4	178.0	178.0	29,057,454	163,244	163,244	1,413,569	4916.4	133.2	29.4
	U350-3.5	1911.0	19.6	178.5	178.5	33,936,916	190,123	190,123	1,638,361	7803.3	133.3	29.3
	U350-4	2183.0	19.8	179.0	179.0	38,826,714	216,909	216,909	1,860,184	11642.7	133.4	29.2
U400	U400-2	1191.0	17.5	202.0	202.0	26,477,288	131,076	131,076	971,312	1588.0	149.1	28.5
	U400-2.5	1488.7	17.6	202.5	202.5	33,123,617	163,573	163,573	1,206,023	3101.5	149.2	28.5
	U400-3	1788.8	17.9	203.0	203.0	39,902,452	196,564	196,564	1,457,942	5366.4	149.4	28.5
	U400-3.5	2086.0	18.1	203.5	203.5	46,590,777	228,947	228,947	1,689,694	8517.8	149.4	28.4
	U400-4	2383.4	18.3	204.0	204.0	53,289,793	261,224	261,224	1,918,365	12711.4	149.5	28.3

4.3 Metoda de montaj

Detaliu de streășină

	TIP	Rezistențe după EN 1993.1.1		
		Întindere	Compresie	Încovoiere
		$N_{t,Rd}$ (kN)	$N_{c,Rd}$ (kN)	$M_{y,Rd}$ (kNm)
U100	U100-1.5	108.08	108.08	3.63
	U100-2	143.99	143.99	4.82
U120	U120-1.5	118.58	118.58	4.56
	U120-2	157.85	157.85	6.06
	U120-2.5	198.10	198.10	7.25
U150	U150-1.5	134.33	134.33	6.10
	U150-2	178.99	178.99	8.10
	U150-2.5	224.35	224.35	10.16
U180	U180-1.5	150.08	150.08	7.79
	U180-2	199.85	199.85	10.35
	U180-2.5	250.67	250.67	12.98
U200	U200-1.5	181.58	181.58	11.11
	U200-2	241.99	241.99	14.77
	U200-2.5	303.17	303.17	18.50
U250	U250-1.5	207.83	207.83	14.98
	U250-2	276.85	276.85	19.92
	U250-2.5	346.85	346.85	24.95
	U250-3	416.08	416.08	29.87
U300	U300-2	311.85	311.85	25.66
	U300-2.5	390.68	390.68	32.13
	U300-3	468.58	468.58	38.47
U350	U350-2	381.85	381.85	37.99
	U350-2.5	477.31	477.31	47.54
	U350-3	573.58	573.58	57.14
	U350-3.5	668.85	668.85	66.54
	U350-4	764.05	764.05	75.92
U400	U400-2	416.85	416.85	45.88
	U400-2.5	521.05	521.05	57.25
	U400-3	626.08	626.08	68.80
	U400-3.5	730.10	730.10	80.13
	U400-4	834.19	834.19	91.43

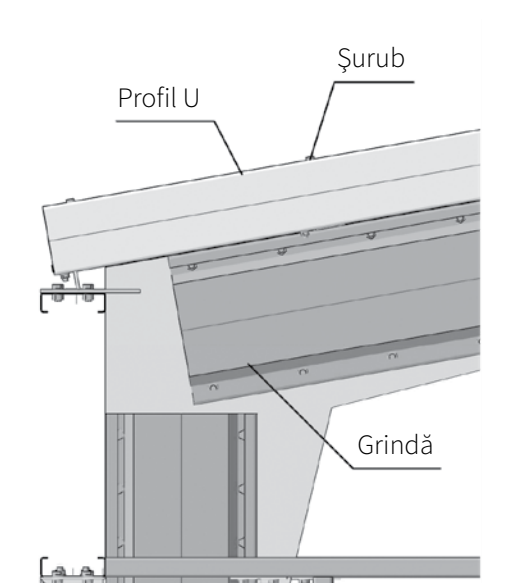
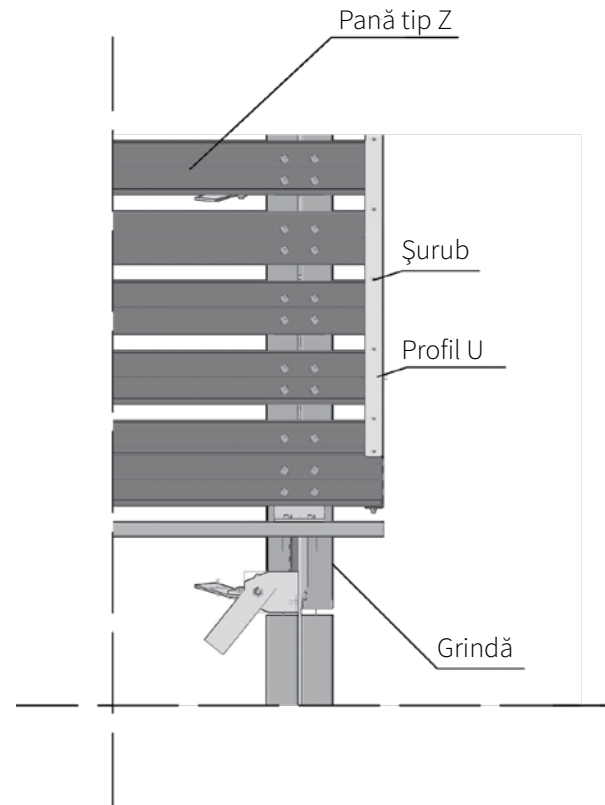

Comparație profile zincate

Clasa de coroziune	Durata de viața a stratului de protecție anticorozivă - ani	
	Tip de oțel	
	S275GD+Zn140	S350GD+Zn275
C1 - foarte scăzută	durata de viață a clădirii	
C2 - scăzută	25	48
C3 - medie	7	14
C4 - ridicată	3	6

Garanția

Durata de garanție a profilelor **TeraSteel** variază în funcție de mediul (gradul de coroziune) în care se utilizează elementele, putând ajunge până la întreaga durată de viață a clădirii.

Ambalare

Profilele metalice ușoare se ambalează în legături de maxim 3t. În vederea ambalării profilele metalice se așează manual pe rigle de lemn așezate pe un plan orizontal. Numărul riglelor suport de lemn este în funcție de lungimea profilelor, iar dispunerea acestora se va face câte o riglă către capetele profilelor și câte o riglă la circa 2-3 m de la celelalte rigle. A se vedea Fig.1

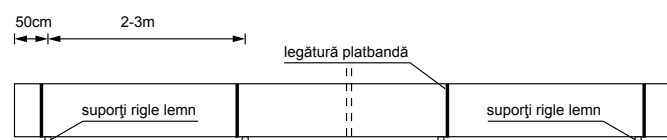

În cazul profilelor C, U și Σ acestea se așează pe rând, primul rând cu inima în jos iar pe următorul rând profilele se așează intercalate cu inima în sus. A se vedea Fig.2.

Profilele de tip Z se așează unul lângă celalalt pe un singur rând. Pentru o mai facilă susținere și așezare a primelor profile pe riglele suport se utilizează saboții de lemn fixați pe riglele

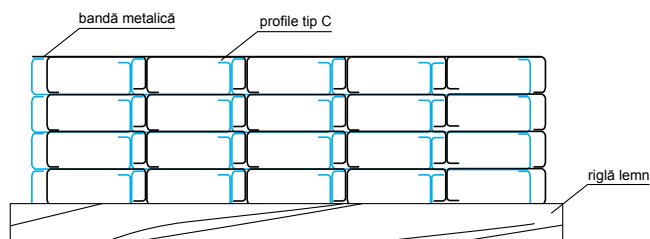

Fig. 2

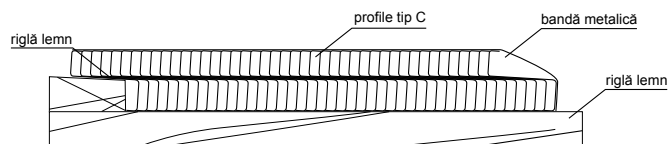
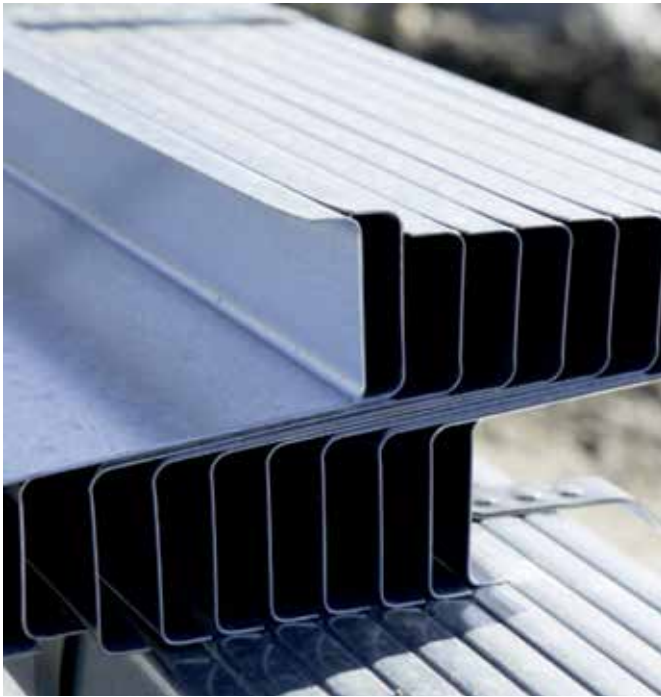

Fig. 3

suport. A se vedea Fig.3.

După așezarea profilelor se procedează la legarea/prinderea profilelor cu benzi metalice utilizându-se mașini manuale sau pneumatice specializate. Numărul de legături/prinderi cu benzi metalice este în funcție de lungimea profilelor de legat, iar dispunerea acestora se va face câte o legare/prindere către capetele profilelor și câte o prindere la circa 2-3 m de la celelalte legări/prinderi. A se vedea Fig.1.





Depozitare

Odată legate, profilele se transportă cu ajutorul motostivitorului la locul de depozitare sau încărcare. Depozitarea pe scurtă durată a profilelor se va face la distanță față de sol, pe rigle suport dispuse ca în fig. 1 pe suprafețe plane, ușor înclinate pe direcția longitudinală a profilelor pentru a permite scurgerea eventualelor ape pluviale.

Transportul

Transportul profilelor se face cu mijloace de transport preferabil acoperite, în legături care se pot suprapune, fixate cu chingi.

Descărcarea

Descărcarea profilelor se face cu dispozitive mecanice: pod rulant cu chingi textile, motostivitor cu furci protejate (cauciuc).

Este interzisă manipularea defectuoasă a profilelor, descărcarea prin basculare, aruncarea, târârea, etc. sau alte manevre care pot produce degradarea profilelor și/sau a stratului de zinc.

Depozitarea pe lungă durată se face în spații acoperite, ferite de umiditate, bine ventilate cu suprafața plană și ușor înclinată pe direcția longitudinală a profilelor. Se interzice depozitarea elementelor în spații cu umiditate ridicată sau medii nocive sau corozive. Se interzice descărcarea profilelor pe timp de ploaie. Dacă totuși se descarcă în condiții de umiditate, profilele se depozitează desfăcute din legătură și cu distanță individuală între ele așezate pe rigle suport ridicate față de sol, pe o suprafață plană ușor înclinată pentru a permite eliminarea apei/umidității și a se preveni apariția ruginii albe sau negre.

Certificări

Elementele structurale din oțel fabricate din lamine formate la rece, sunt produse de către TeraSteel într-un sistem al controlului producției în fabrică certificată de SRAC CERT SRL, numărul certificatului **2003 - CPR - 726**.

Pe baza acestei certificări TeraSteel elaborează declarație de performanță și aplica marcajul de conformitate **CE** pe produsele livrate.



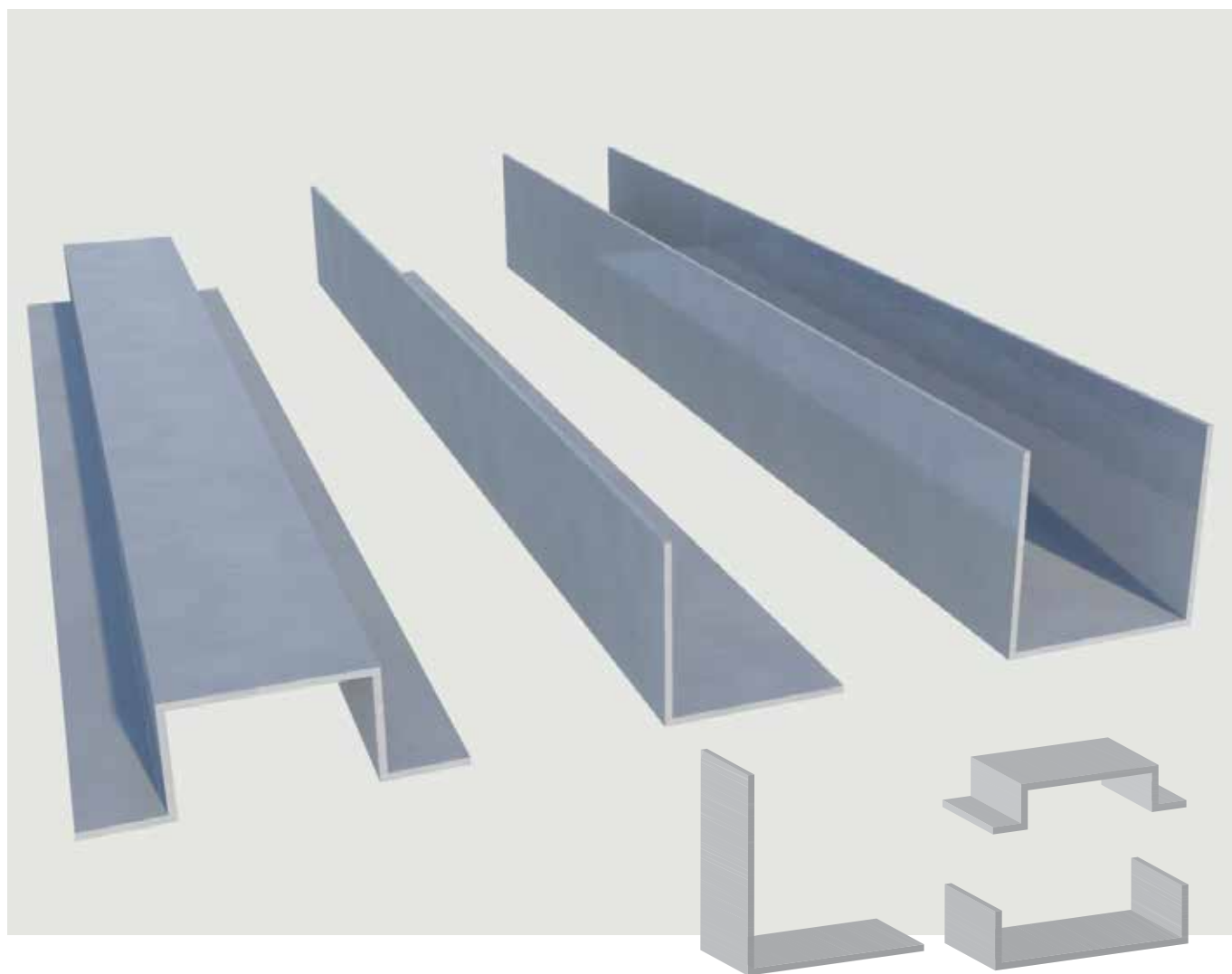

III. PROFILE GHIDAJ ȘI ALINIERE L,Ω,U

III.1 Profil zincat L

Lățimi desfășurate: 100mm, 120mm, 140mm, 160mm,
180mm și 200mm

Material: Tablă zincată

Grosime: 1.50mm și 2.00mm

Lungime: 6000mm

Notă: Dimensiunea minimă a laturilor este de 30mm (A_{min} ,
 $B_{min} = 30mm$)

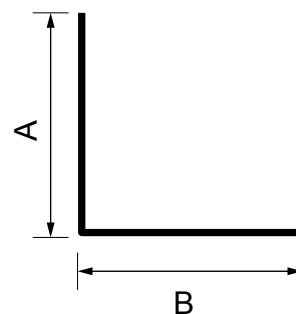

III.2 Profil zincat U

Lățimi desfășurate: 100mm, 120mm, 140mm, 160mm,
180mm și 200mm

Material: Tablă zincată

Grosime: 1.50mm și 2.00mm

Lungime: 6000mm

Notă: Dimensiunea minimă a laturilor este: $A_{min} = 30mm$

Latura B trebuie să fie cu minim 20 mm mai mare decât A ($B \geq A + 20mm$)

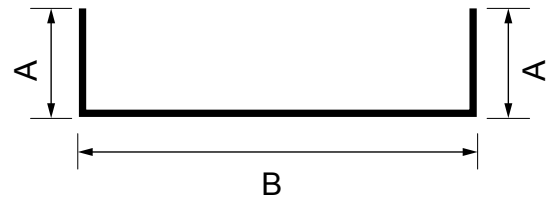

III.3 Profil zincat Ω

Lățimi desfășurate: 100mm, 120mm, 140mm, 160mm,
180mm și 200mm

Material: Tablă zincată

Grosime: 1.50mm și 2.00mm

Lungime: 6000mm

Notă: Dimensiunea minimă a laturilor este de 30mm ($A_{min}, C_{min} = 30mm$)

Latura B trebuie să fie cu minim 20 mm mai mare decât A ($B \geq A + 20mm$)

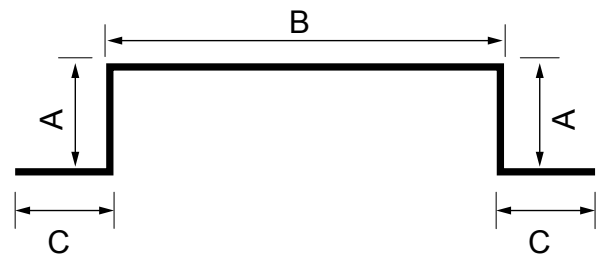



Hală producție Cluj Napoca - 4.500 mp

IV. HALE LA CHEIE

Oferim soluții complete de hale la cheie: proiectare (conform Eurocod-urilor), producție și montaj pentru Sistemul de Hale TeraSteel.

Sistemul cuprinde:

- proiect de fundații ștampilat și verificat MLPAT;
- proiectul de rezistență a structurii metalice cu ștampilă de verificator atestat MLPAT cerința A2;
- panouri sandwich cu spumă PUR sau PIR pentru închideri (pereți și acoperiș);
- accesorii de mascare din tablă zincată și vopsită cu vopsea poliesterică (25 micron).
- tâmplărie de tip PVC sau Aluminiu în orice configurație dorită de client;
- luminatoare, trape desfumare inclusiv sistem de ventilație zilnică;
- uși secționale industriale cu acționări manuale sau electrice;
- grinzi din profile ambutisate zincate;
- stâlpi din profile ambutisate zincate;
- contravanturiri orizontale și verticale;
- rânduri de pane pe fiecare versant;
- rânduri de rigle de fațadă pentru prinderea panourilor;
- plăci, gusee la baza stâlpului și piese de legătură între toate elementele principale de rezistență;
- șuruburi de prindere de înaltă rezistență electrozincate grupa 8.8;
- asistență tehnică din partea proiectanților și managerului de proiect.

Un singur furnizor pentru toate nevoile Proiectului dumneavoastră.

Avantajele Sistemului de hale TeraSteel

- consum mic de oțel care conduce la un cost scăzut de construire (EUR/m²)
- cantitate de lucrări de infrastructură mai mici față de soluția clasică
- materiale durabile, costuri de întreținere reduse
- montaj facil, modularitate ridicată
- clădiri “verzi” cu o amprentă de CO₂ redusă
- pot fi demontate și relocate cu ușurință

TeraSteel vă pune la dispoziție un estimator online de prețuri pentru hale metalice
www.terasteel.ro/configurator





Hală procesare pui Ungaria - 16.000 mp



Hală producție Vâlcea - 1.500 mp



Hală depozit Rm. Vâlcea - 3150 mp



V. FÂȘII ZINCATE

Furnizăm fâșii zincate la dimensiunile solicitate de client. Tabla de oțel zincat este conform standardelor SR EN 10143 și SR EN 10346.

Caracteristici:

- Calitate material: tablă S350GD și DX51D
- Acoperire de zinc: 100-275 gr/mp
- Grosime tablă: 0,5 mm - 4 mm
- Lățimi: 23 mm - 1500 mm
- Diametru interior rolă: 508-510 mm

Ambalarea

Fâșiile zincate sunt rigidizate cu bandă metalică, etichetate individual și depozitate pe europaleți de lemn. Greutatea fiecărui europalet se stabilește în funcție de posibilitățile de descărcare ale clientului.

TOGETHER WE
BUILD BETTER

